

**APPENDIX L**  
**SCAFFOLDS, WORK STANDS, AND**  
**PLATFORMS**

**FIGURE L-1**

**SCAFFOLDS**

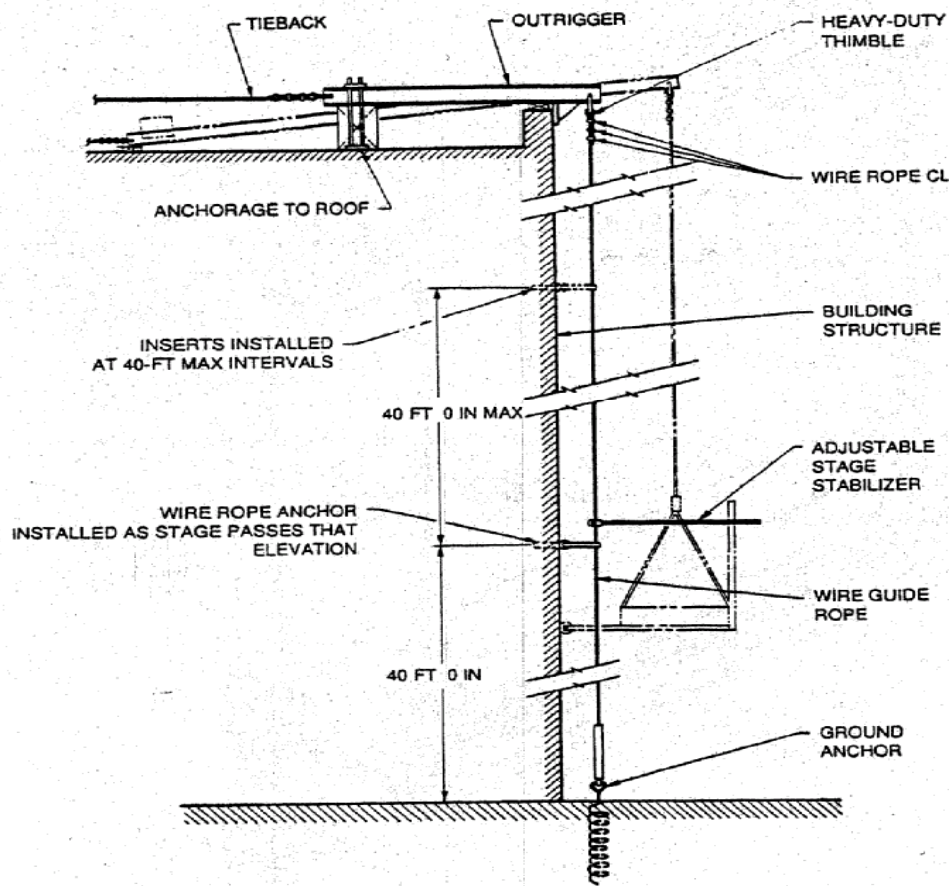

**Two-Point Suspension Scaffold  
Ground-Rigged Sway Control**

EM 385-1-1  
3 Nov 03

### FIGURE L-1 (CONTINUED)

### SCAFFOLDS

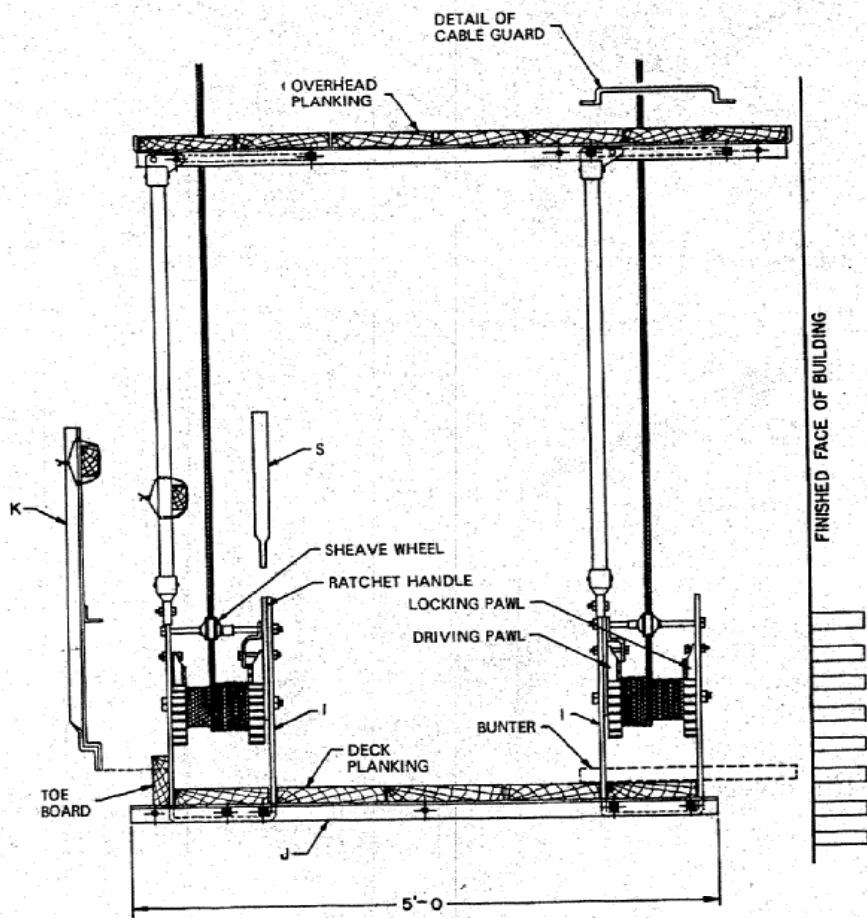
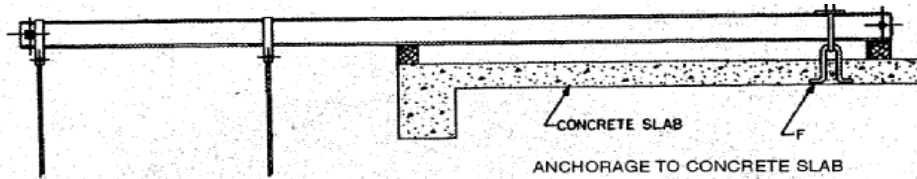

Masons' Adjustable  
Multiple-Point Suspension Scaffold

FIGURE L-1 (CONTINUED)

SCAFFOLDS

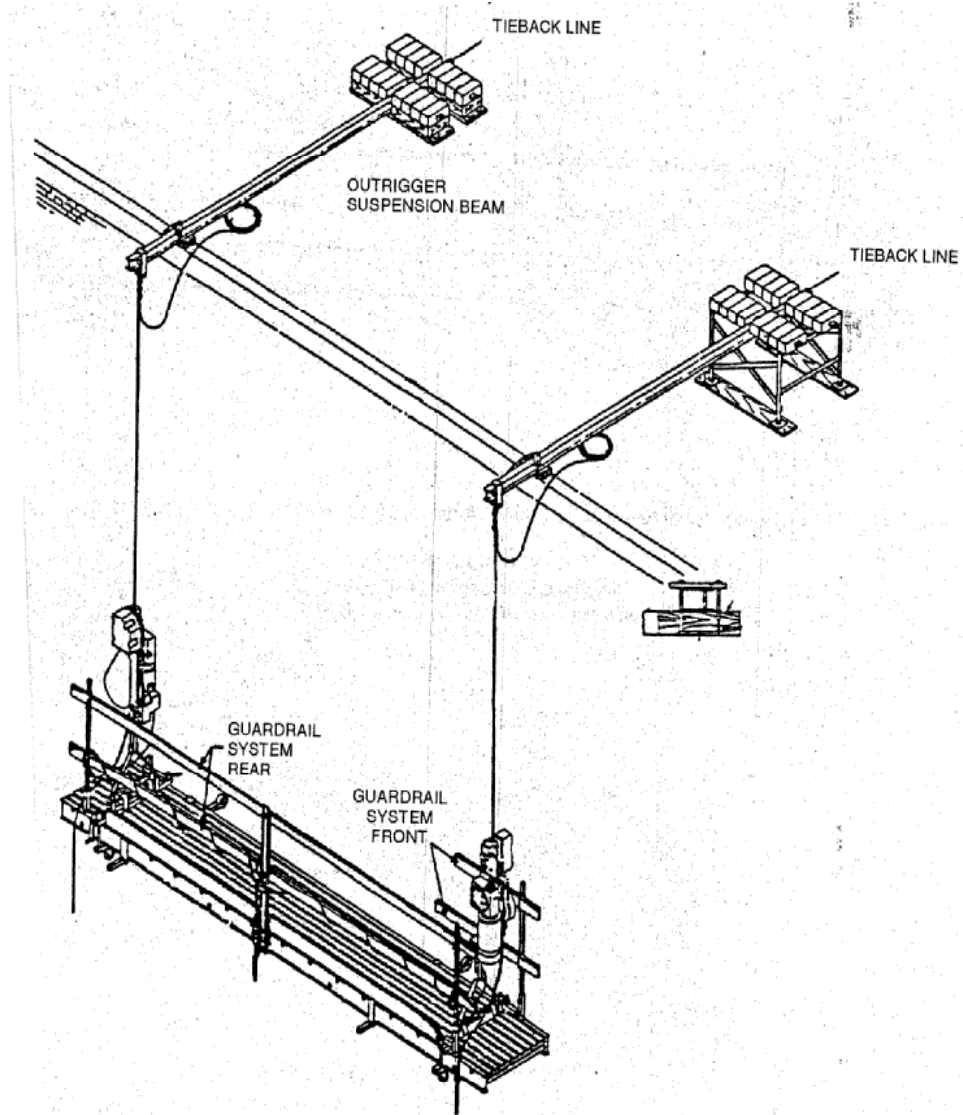

Two-Point Suspension Scaffold  
with Powered Traction Hoists

EM 385-1-1  
3 Nov 03

### FIGURE L-1 (CONTINUED)

### SCAFFOLDS

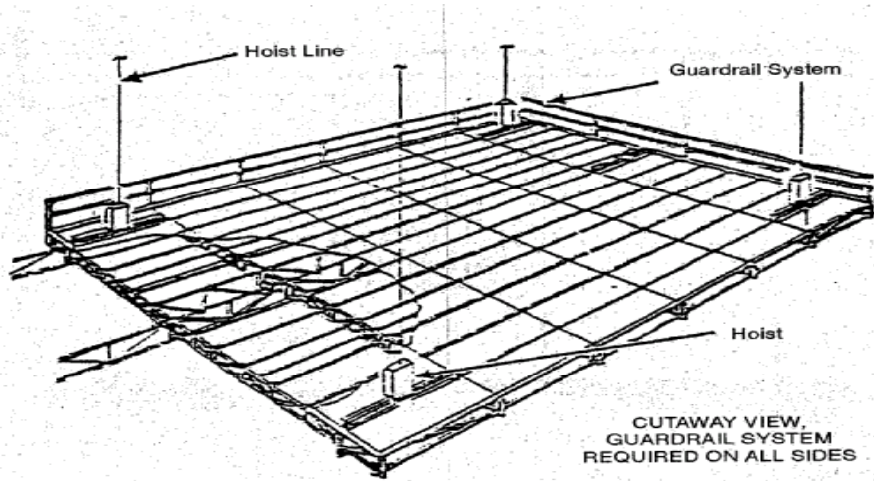

#### Multiple-Point Suspension Scaffold

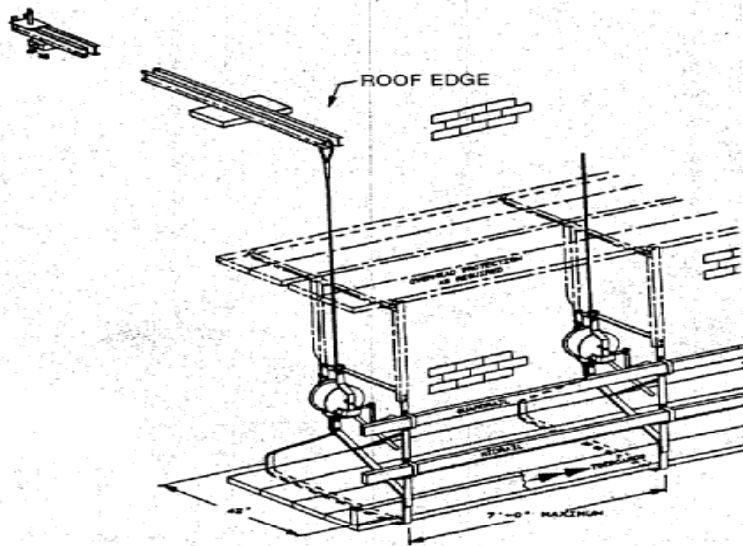

#### Light-Duty Masons' Adjustable Multiple-Point Suspension Scaffold

FIGURE L-1 (CONTINUED)

SCAFFOLDS

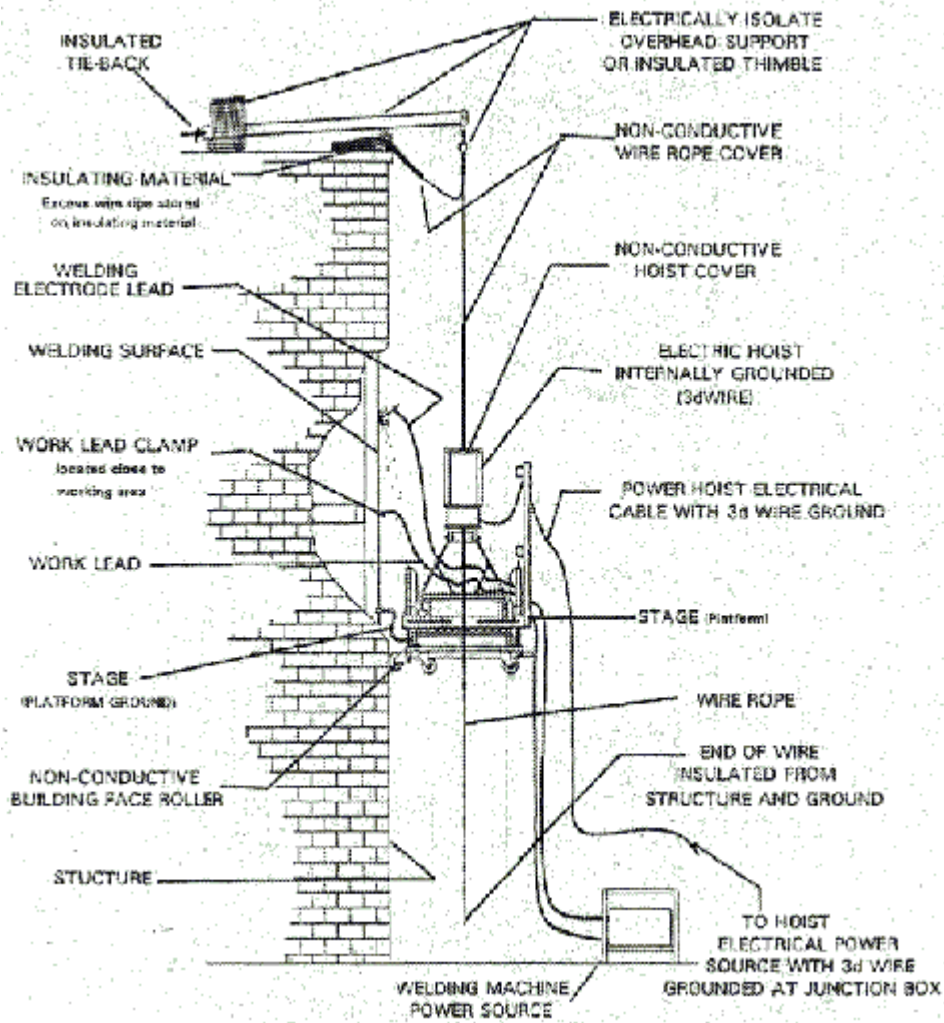

EM 385-1-1  
3 Nov 03

**FIGURE L-1 (CONTINUED)**

**SCAFFOLDS**

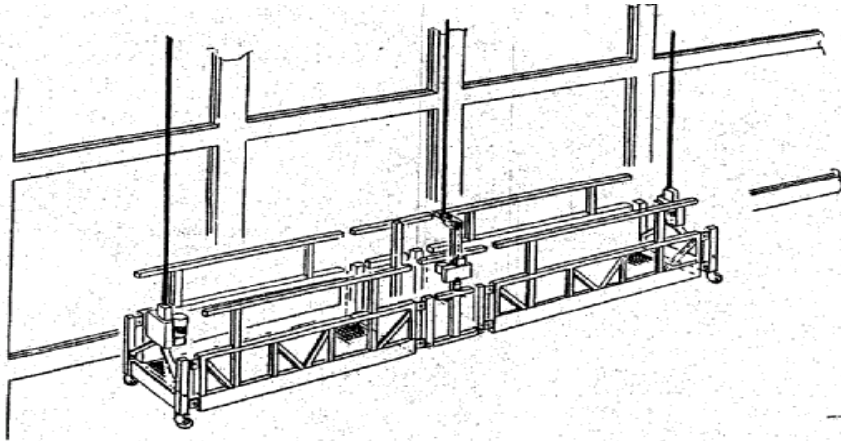

**Modular Suspended Scaffold**

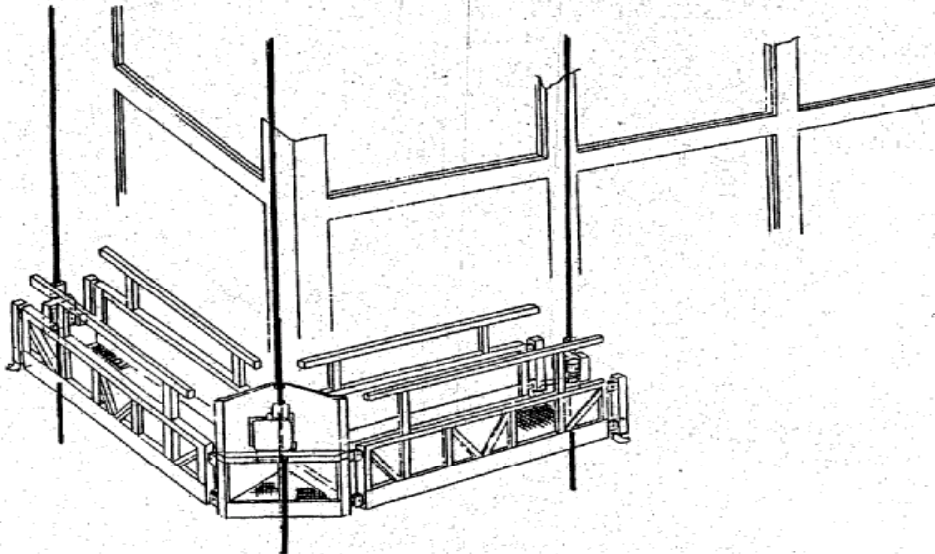

**Modular Suspended Scaffold with an Angled Section**

**FIGURE L-1 (CONTINUED)**

**SCAFFOLDS**

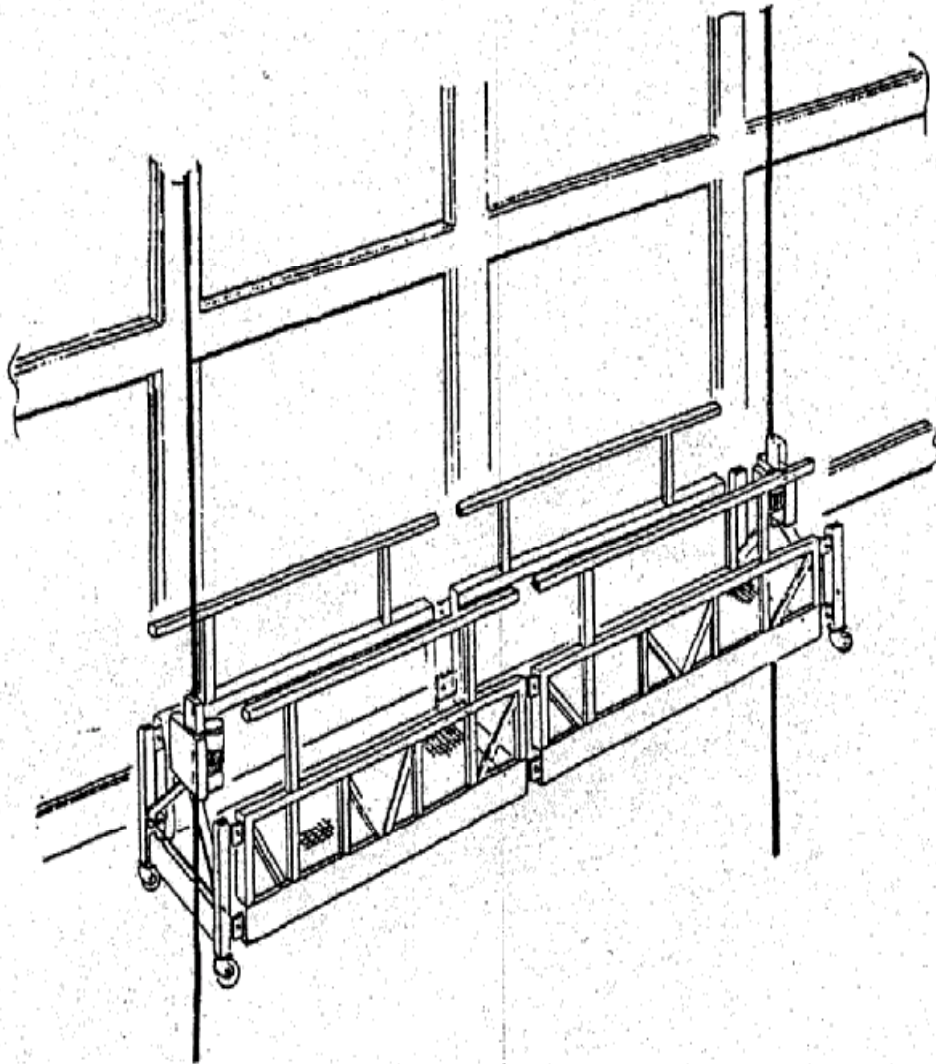

**Two-Point Modular Suspended Scaffold**

EM 385-1-1  
3 Nov 03

### FIGURE L-1 (CONTINUED)

### SCAFFOLDS

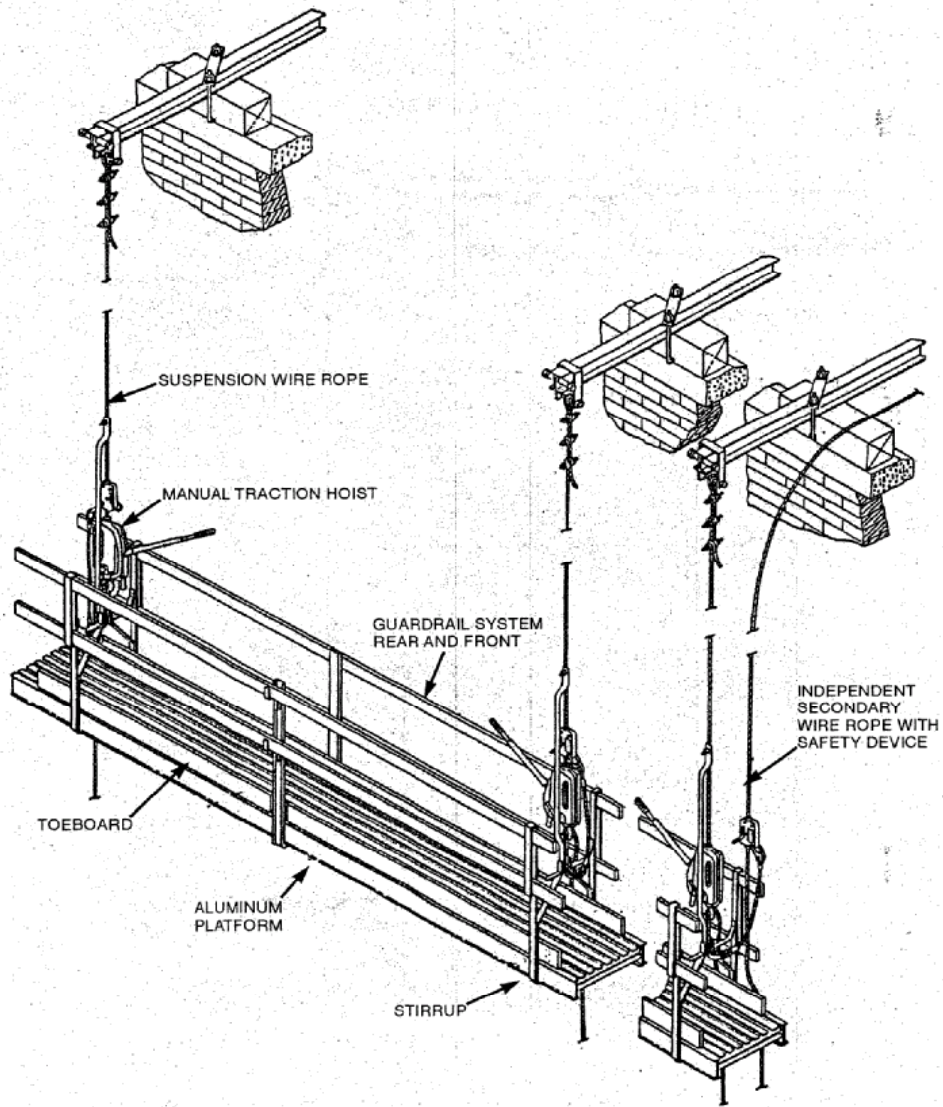

**Two-Point Suspension Scaffold  
with Manual Traction Hoists**



**FIGURE L-1 (CONTINUED)**

**SCAFFOLDS**

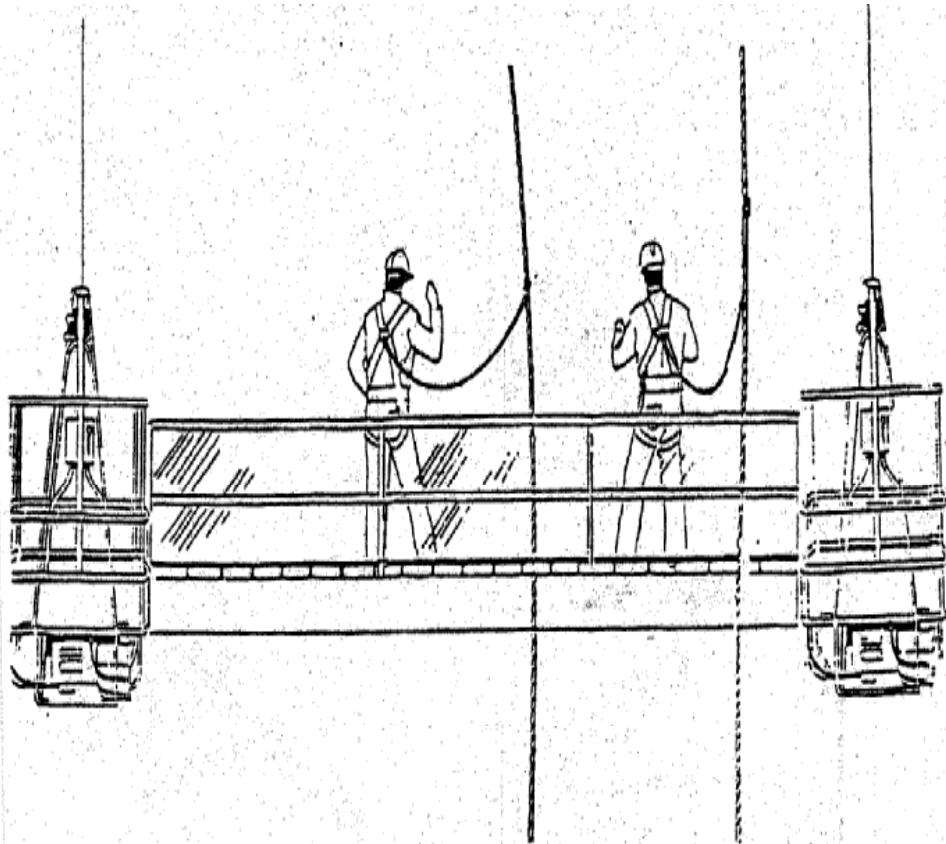

**Two-Point Suspension Scaffold  
with Powered Winding Drum Hoists**

EM 385-1-1  
3 Nov 03

**FIGURE L-1 (CONTINUED)**  
**SCAFFOLDS**

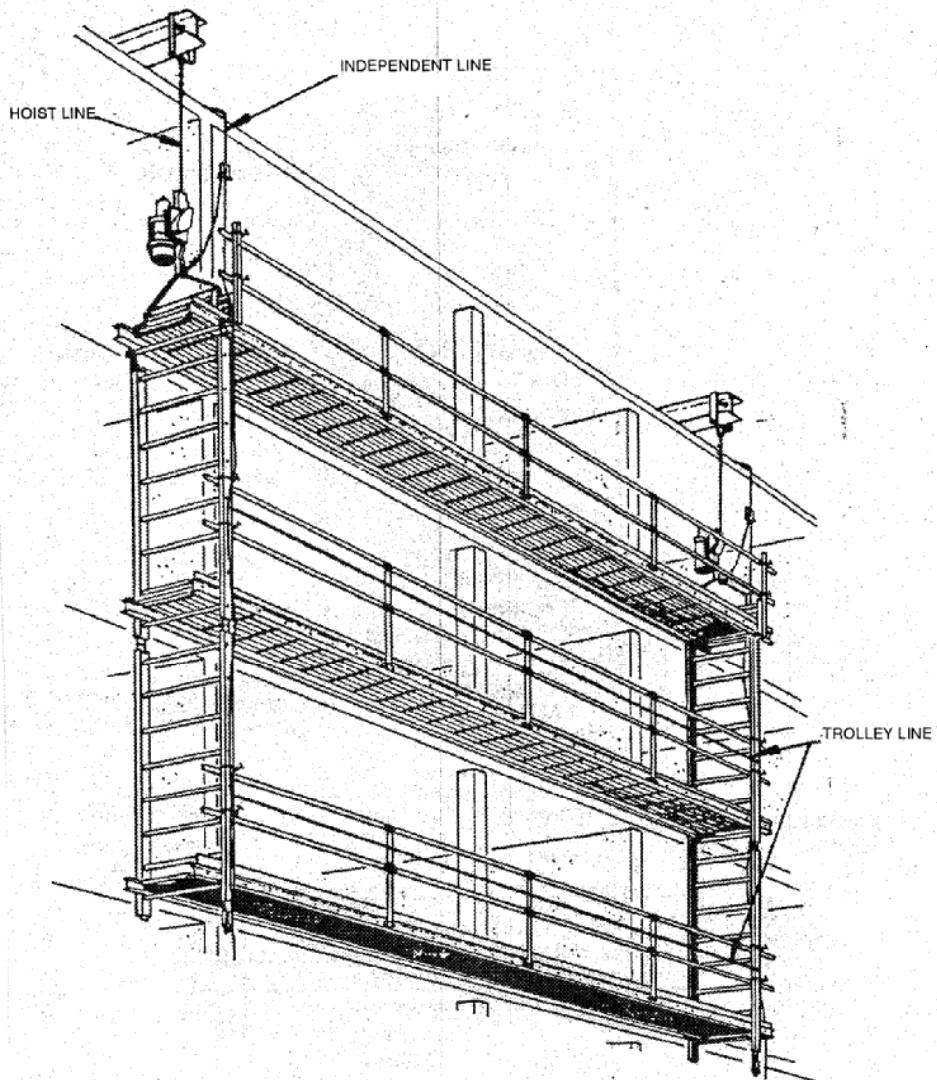

**Multiple-Level Suspended Scaffold  
with Powered Hoists**

FIGURE L-1 (CONTINUED)

SCAFFOLDS

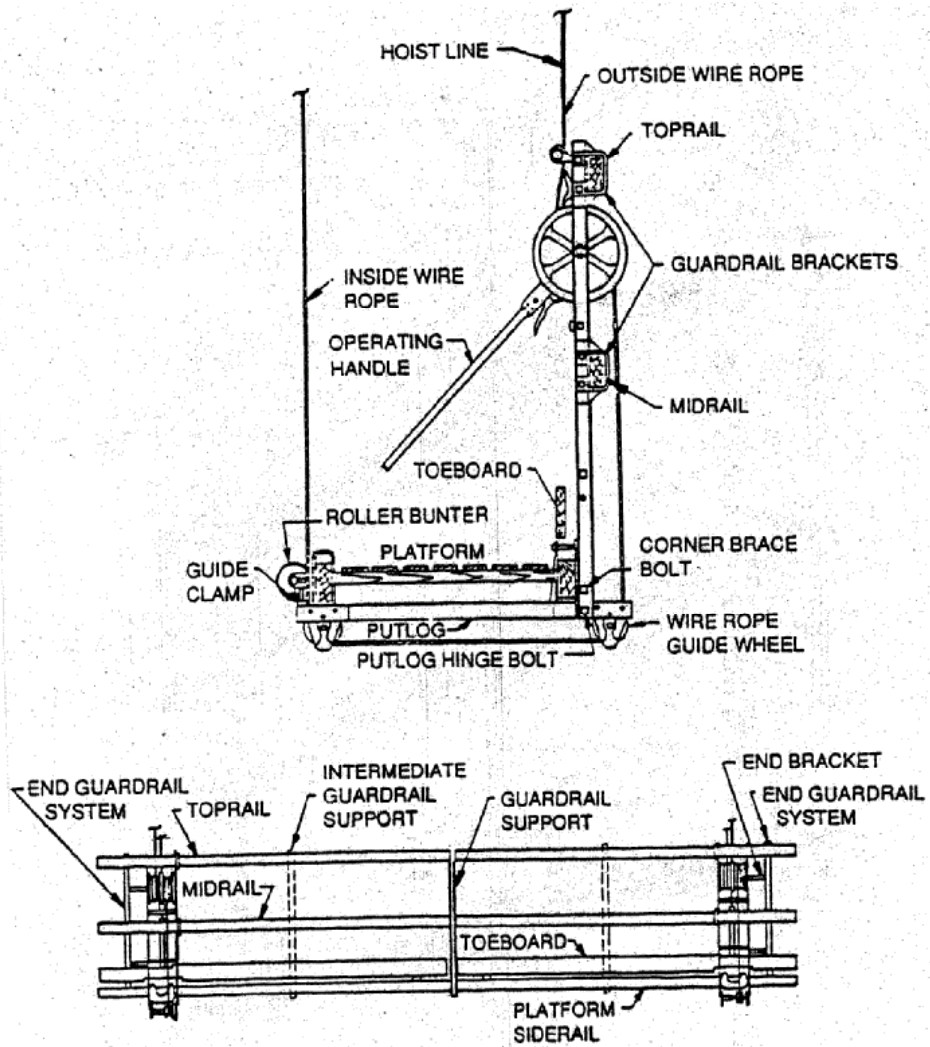

Stone Setters' Adjustable  
Manual Multiple-Point Suspension Scaffold

EM 385-1-1  
3 Nov 03

**FIGURE L-1 (CONTINUED)**

**SCAFFOLDS**

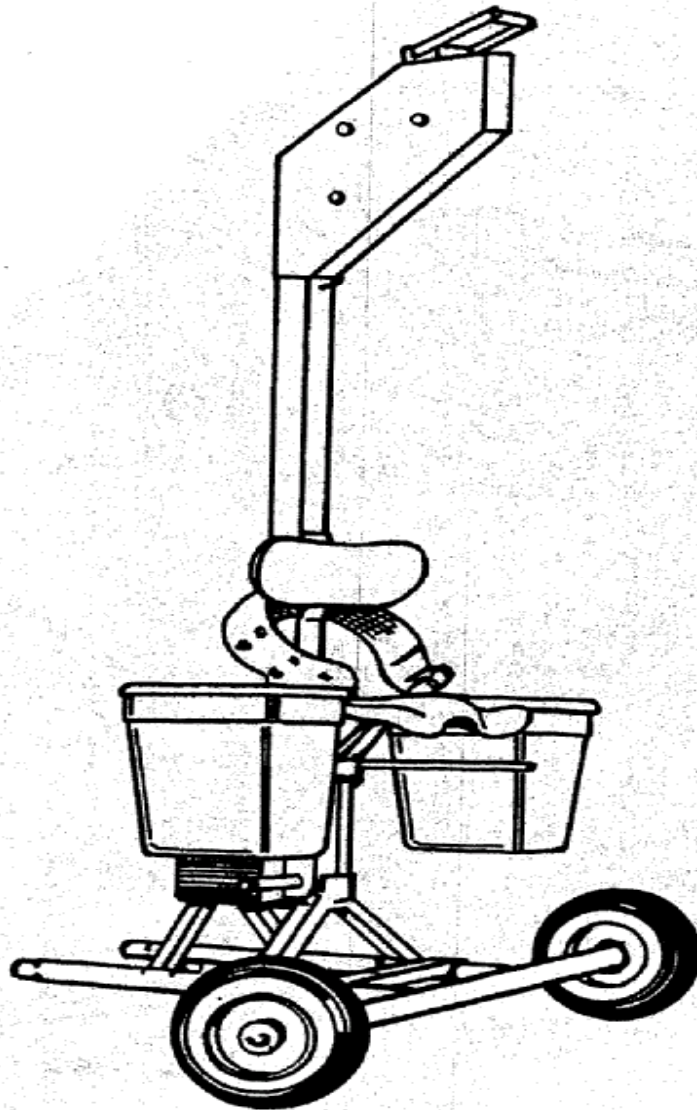

**Boatswains' Chair (Powered)**

**FIGURE L-1 (CONTINUED)**

**SCAFFOLDS**

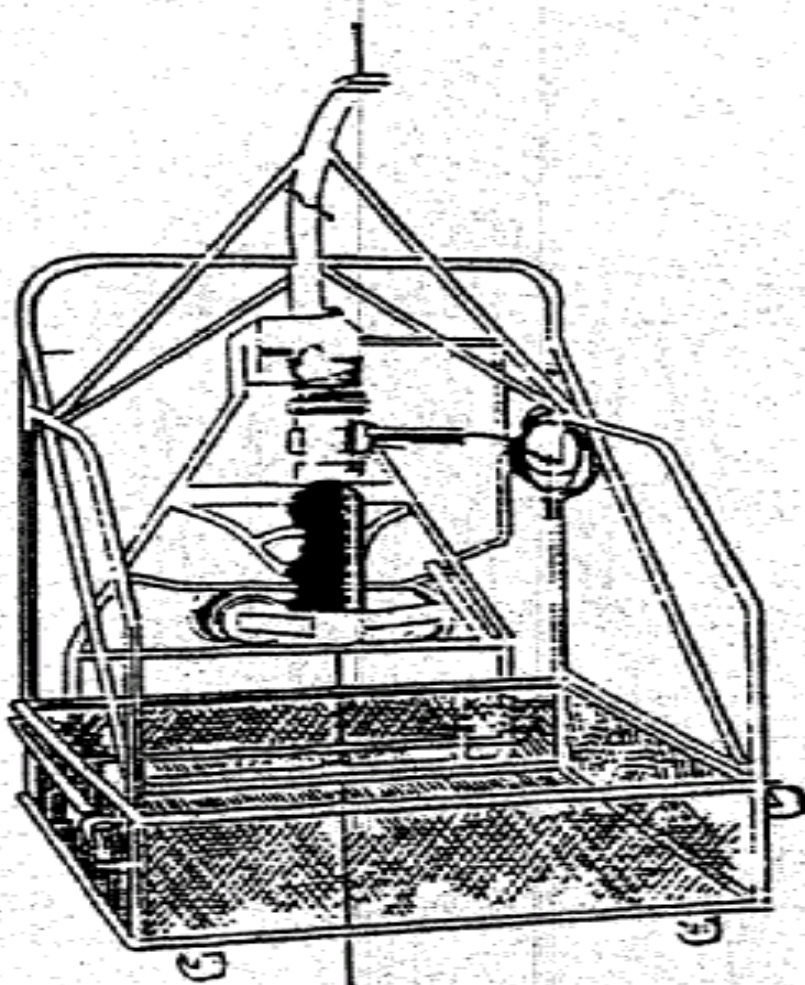

**Single-Point Suspension Scaffold  
with Powered Traction Hoist**

**FIGURE L-1 (CONTINUED)**

**SCAFFOLDS**

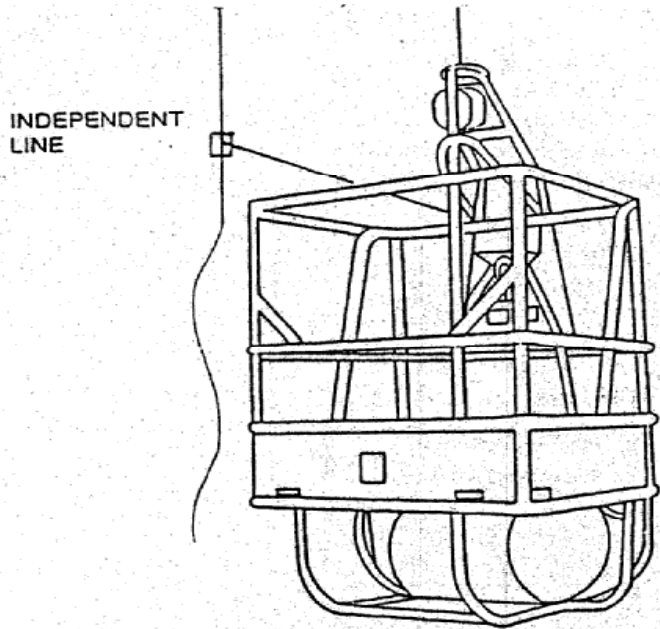

**Single-Point Suspension Scaffold  
with Winding Drum Hoist**

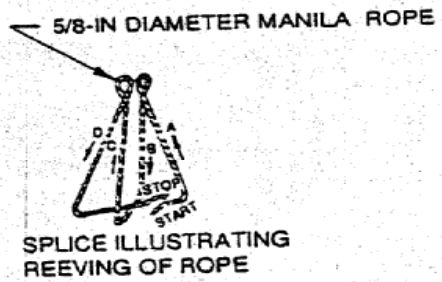
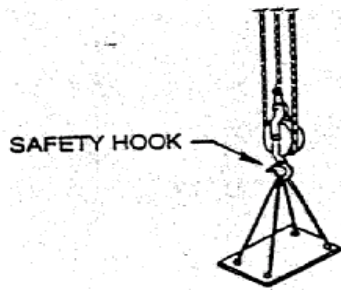

**Boatswains' Chair (Manual)**

FIGURE L-1 (CONTINUED)

SCAFFOLDS

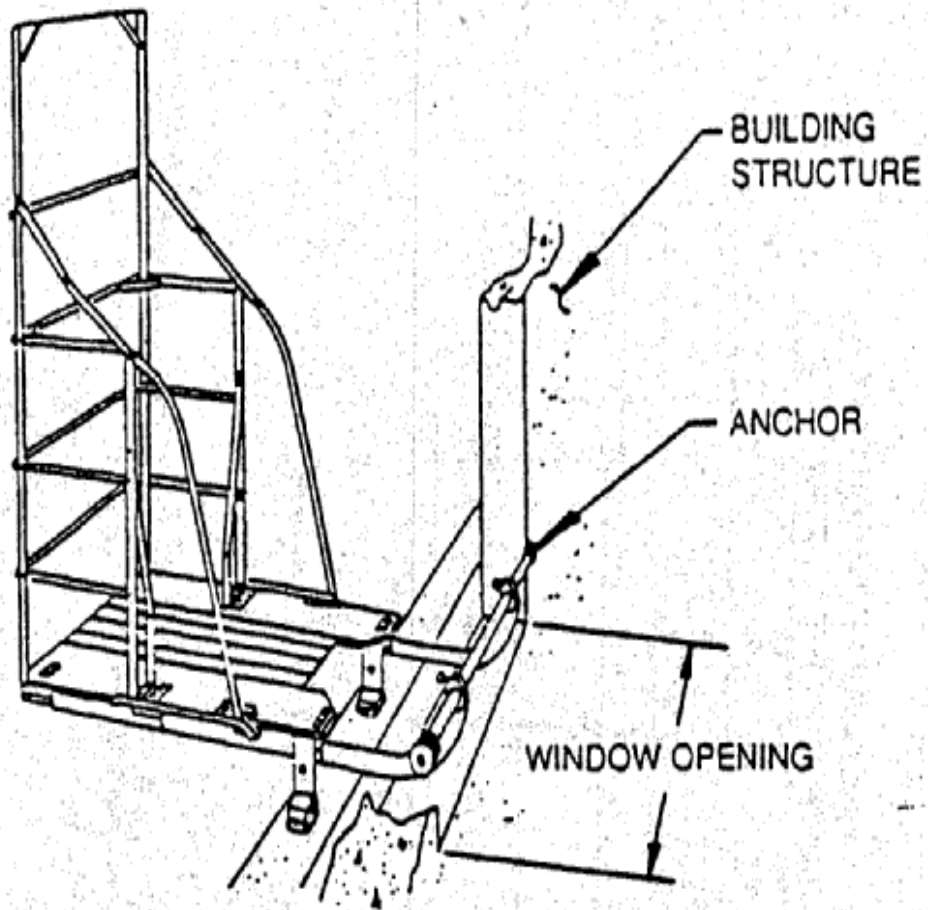

Window Jack Scaffold

**FIGURE L-1 (CONTINUED)**

**SCAFFOLDS**

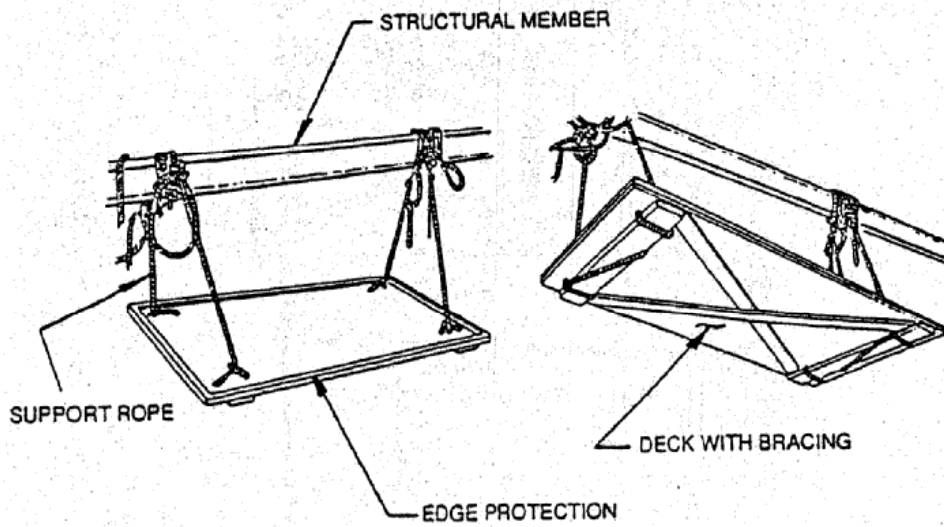

**Float Scaffold**

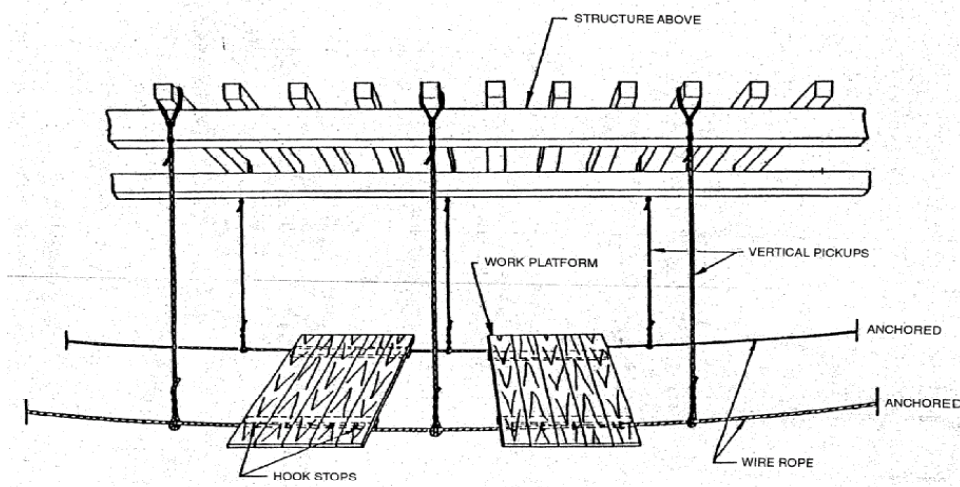
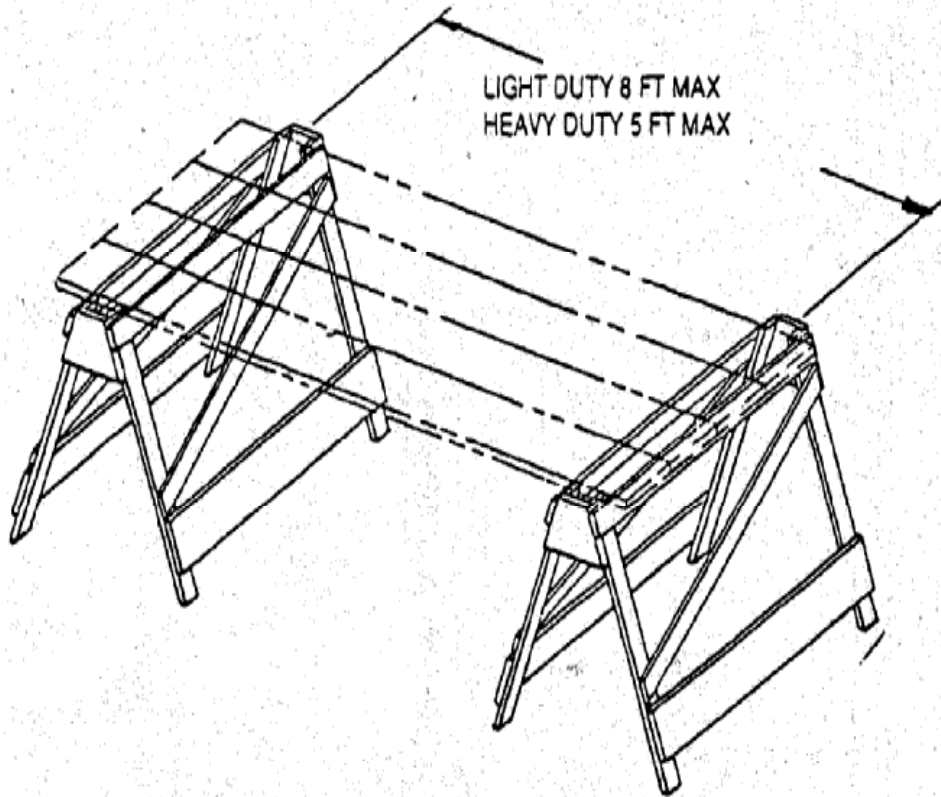

**Figure. Catenary Scaffold**



**FIGURE L-1 (CONTINUED)**

**SCAFFOLDS**



**Horse Scaffold**

EM 385-1-1  
3 Nov 03

**FIGURE L-1 (CONTINUED)**

**SCAFFOLDS**

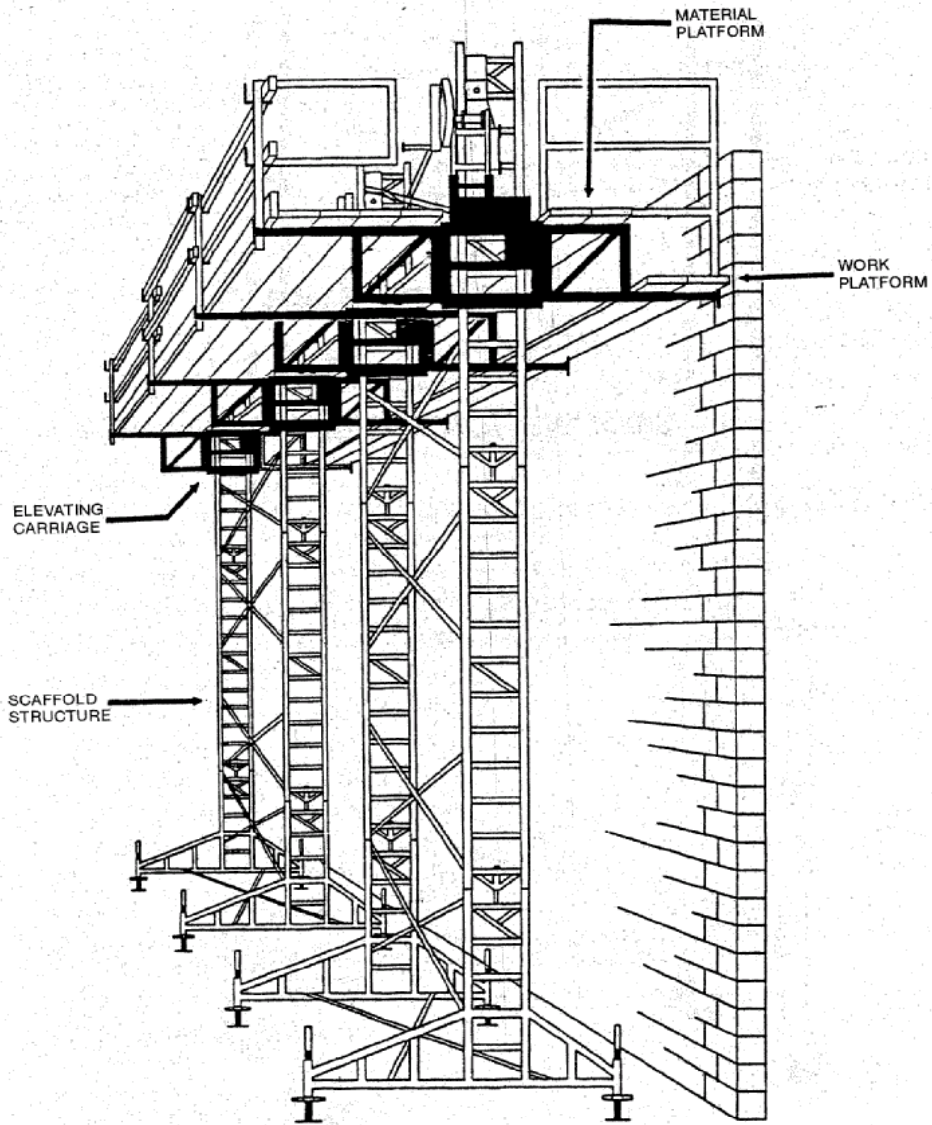

**Adjustable Scaffold**

FIGURE L-1 (CONTINUED)

SCAFFOLDS

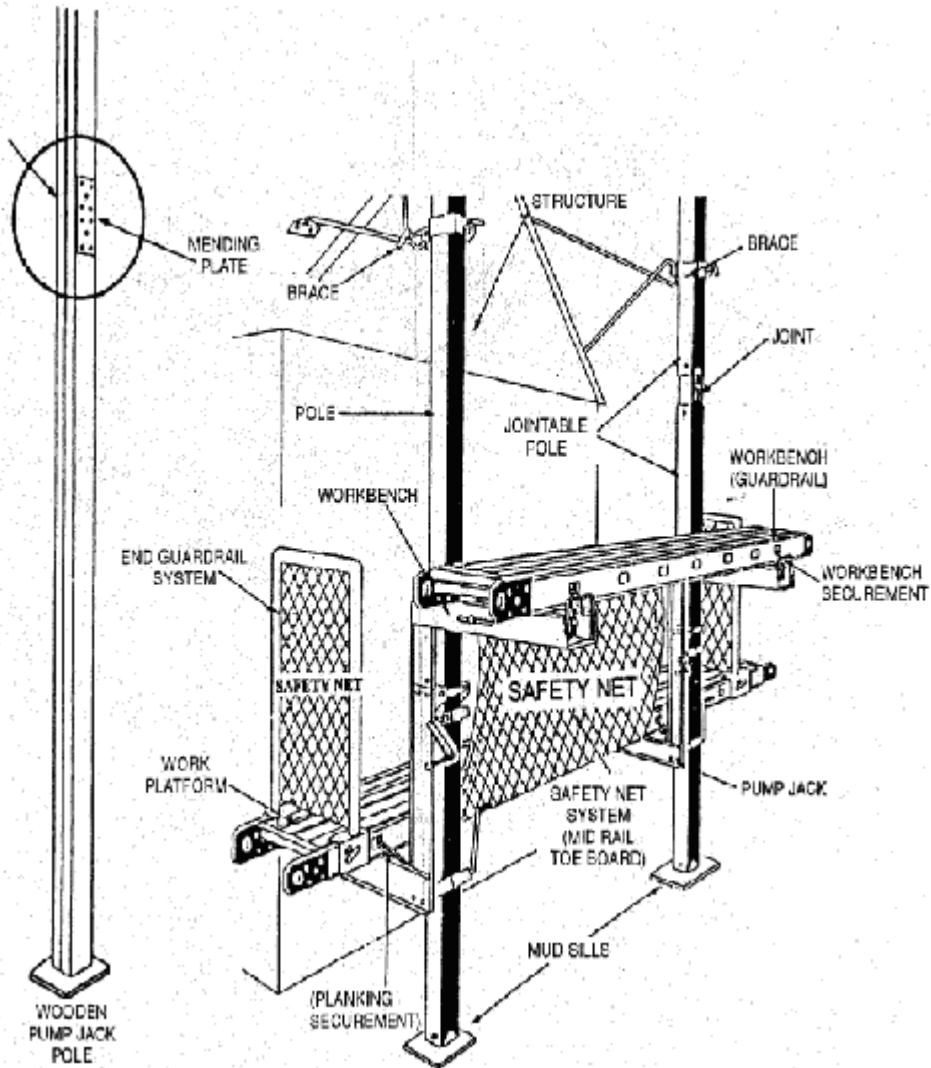

EM 385-1-1  
3 Nov 03

**FIGURE L-1 (CONTINUED)**

**SCAFFOLDS**

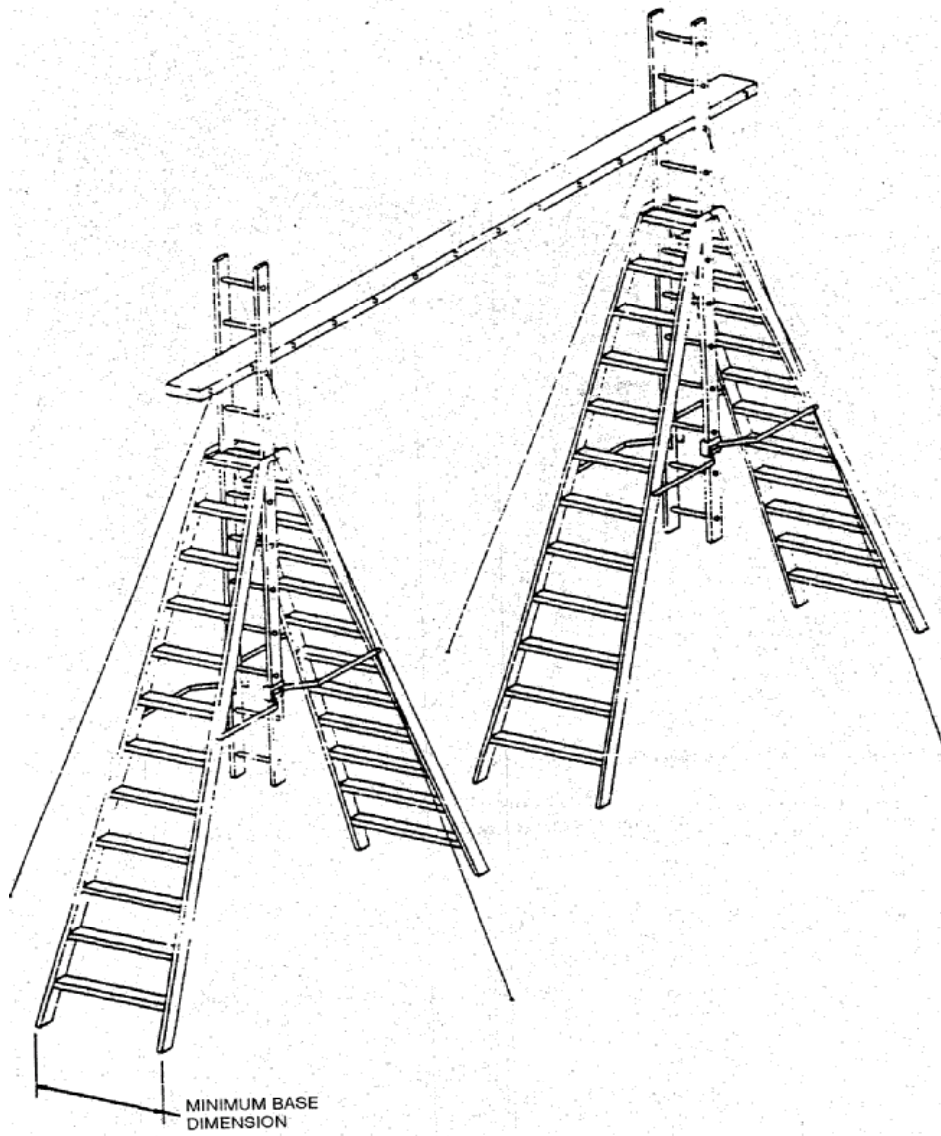

**Extension Trestle Ladder Scaffold**

**FIGURE L-1 (CONTINUED)**

**SCAFFOLDS**

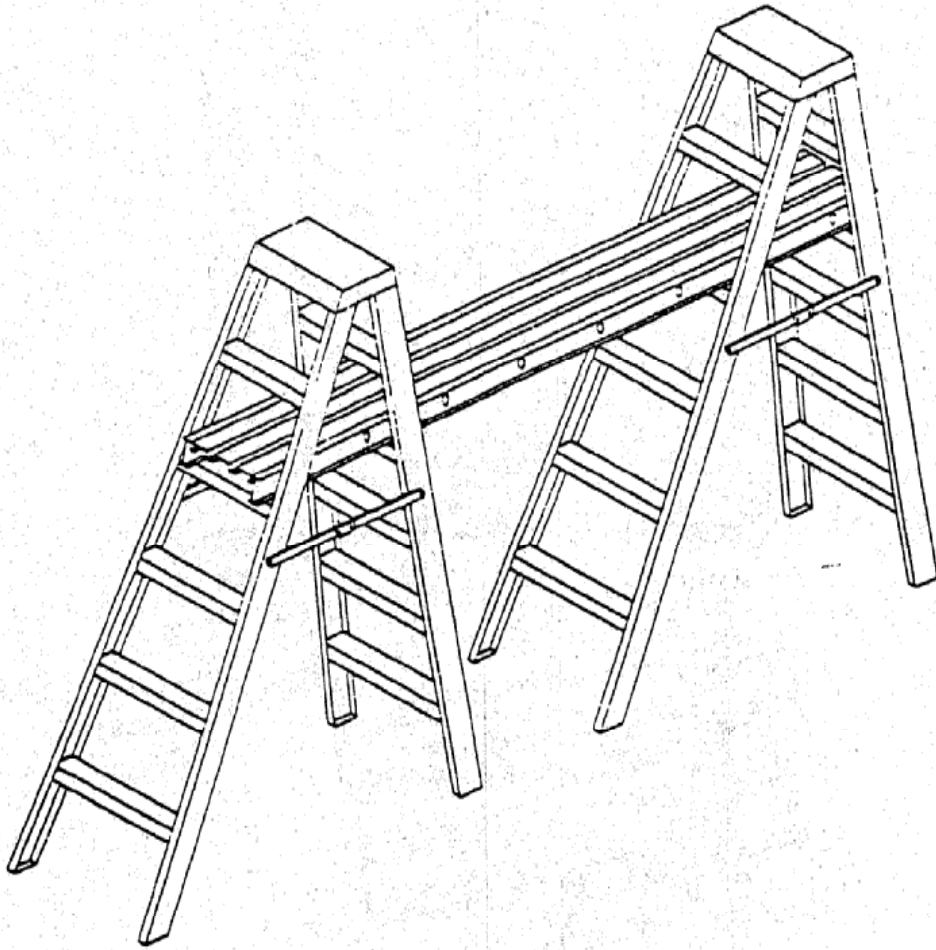

**Free-Standing Ladder Scaffold**

**FIGURE L-1 (CONTINUED)**

**SCAFFOLDS**

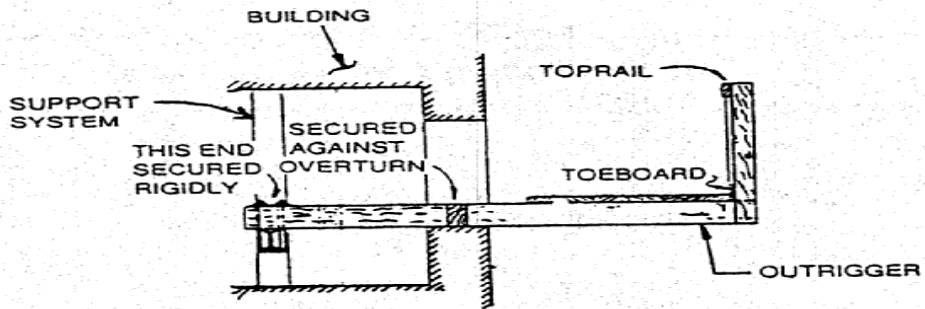

**Outrigger Scaffold**

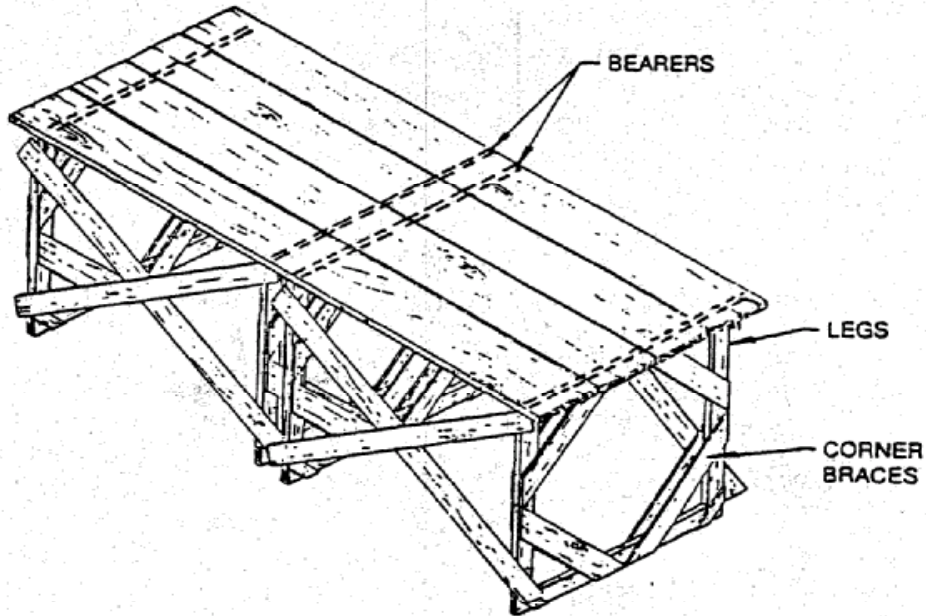

**Bricklayers' Square Scaffold**

FIGURE L-1 (CONTINUED)

SCAFFOLDS

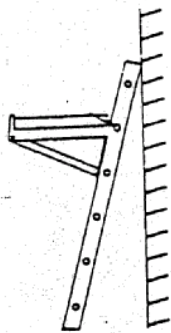
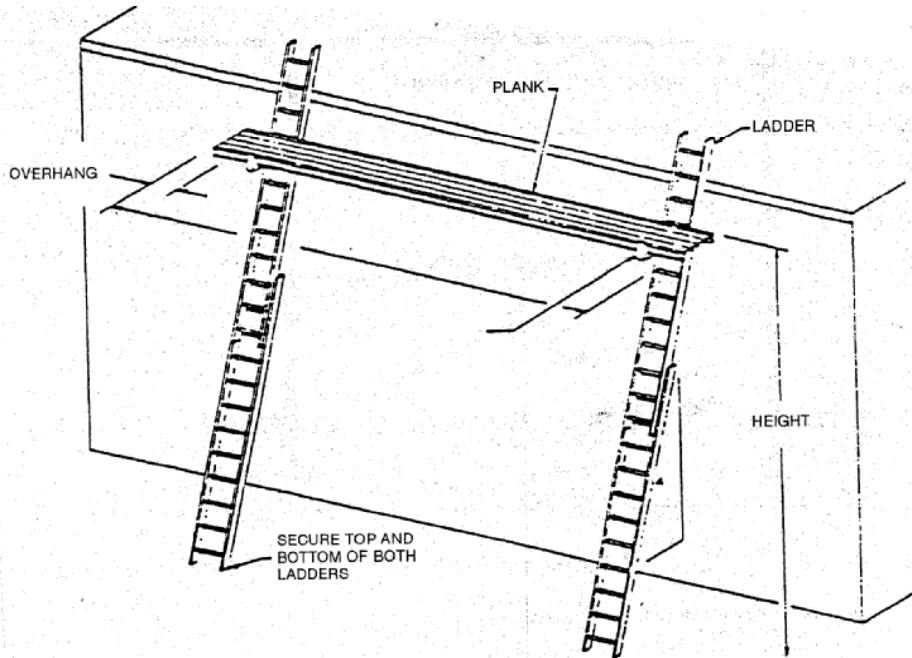

JACK INSTALLED ON SIDE OF LADDER AWAY FROM SURFACE

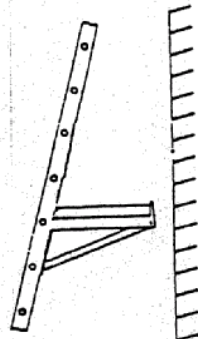

JACK INSTALLED ON SIDE OF LADDER TOWARD SURFACE

Ladder Jack Scaffold

**PROHIBITED**

EM 385-1-1  
3 Nov 03

**FIGURE L-1 (CONTINUED)**

**SCAFFOLDS**

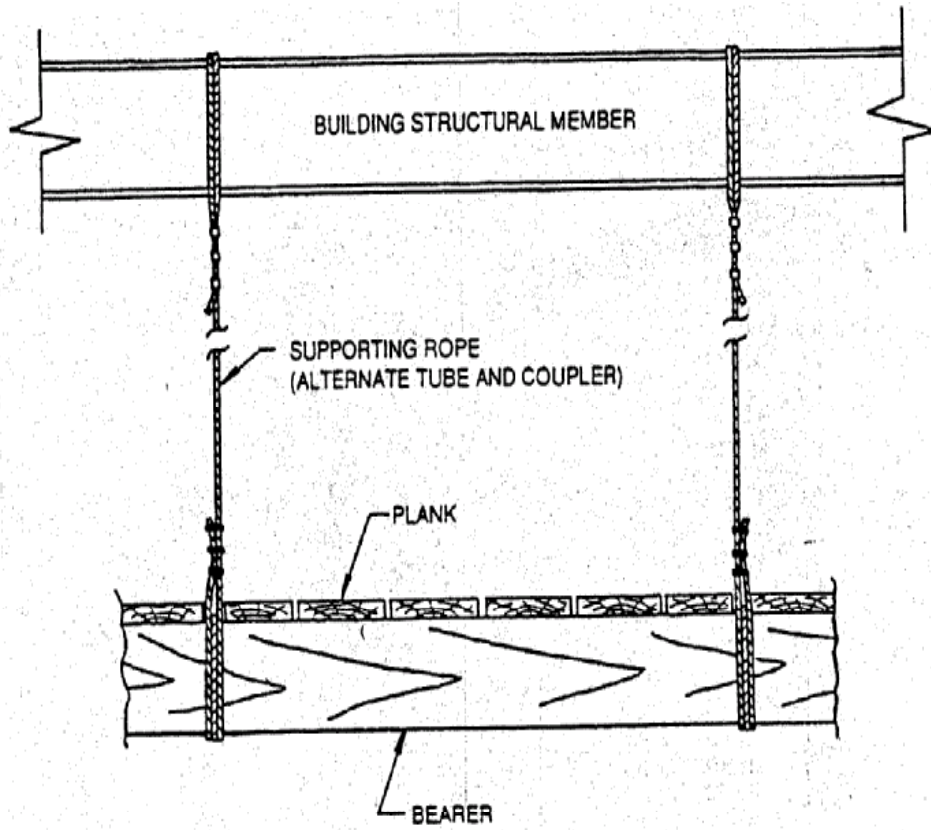

**Interior Hung Scaffold**



**FIGURE L-1 (CONTINUED)**

**SCAFFOLDS**

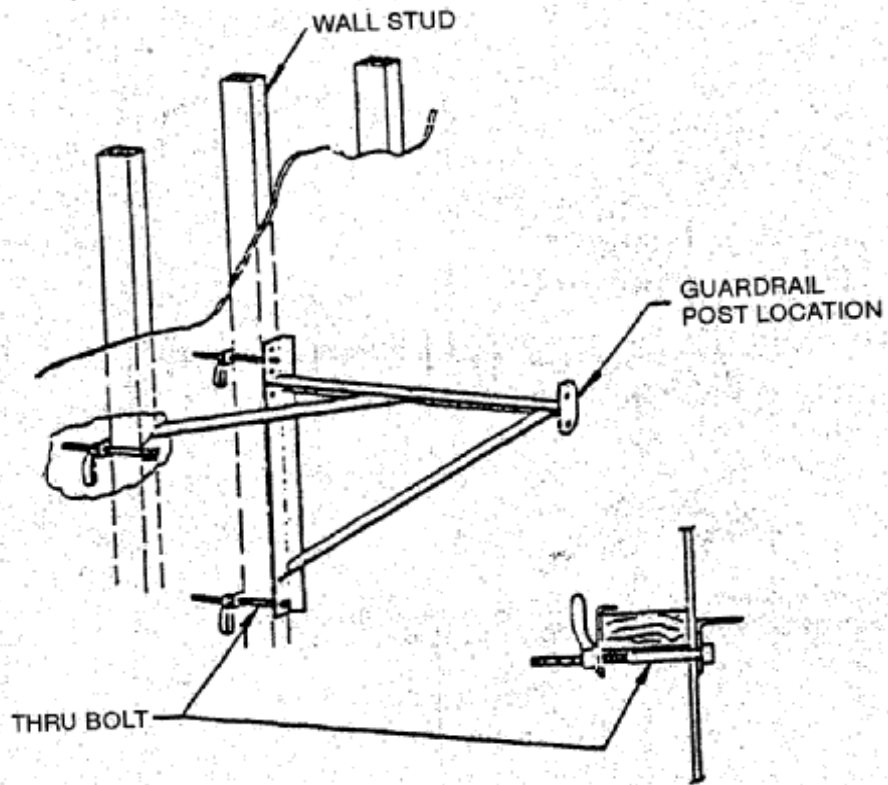

**Metal Carpenter Bracket**

EM 385-1-1  
3 Nov 03

**FIGURE L-1 (CONTINUED)**

**SCAFFOLDS**

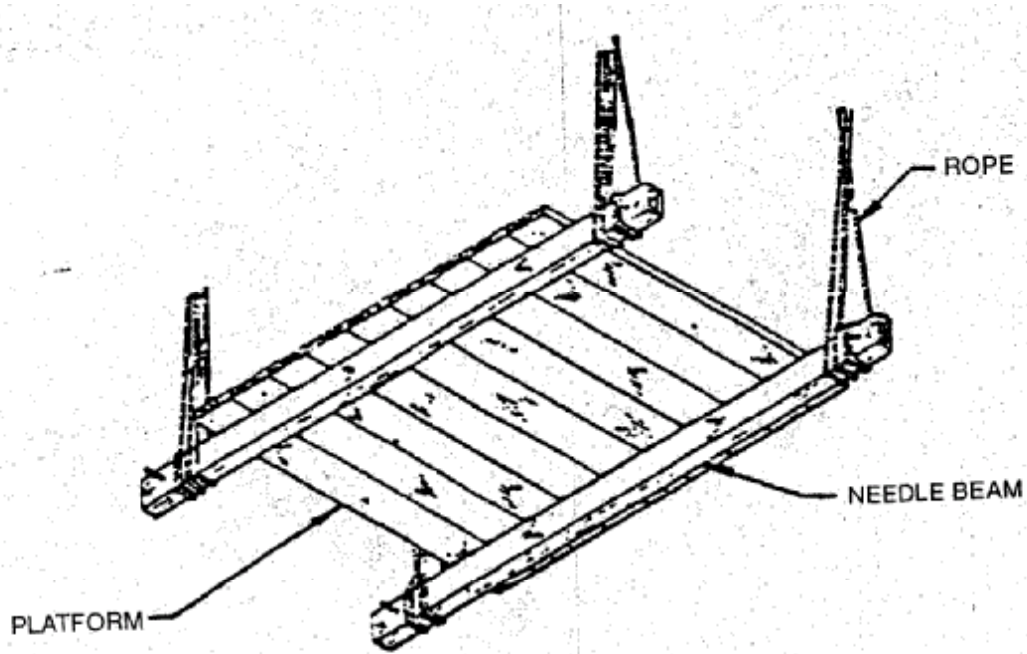

**Needle Beam Scaffold**

FIGURE L-1 (CONTINUED)

SCAFFOLDS

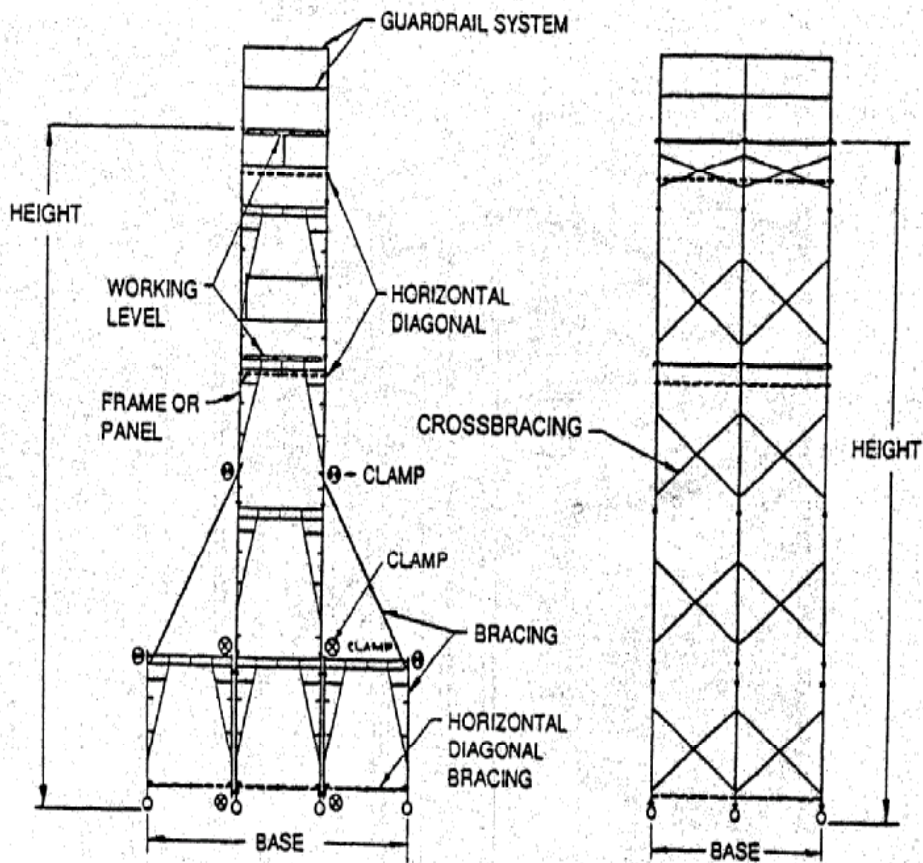

Manually Propelled Mobile Scaffold (2)  
(Fabricated Tubular Frame)

EM 385-1-1  
3 Nov 03

### FIGURE L-1 (CONTINUED)

### SCAFFOLDS

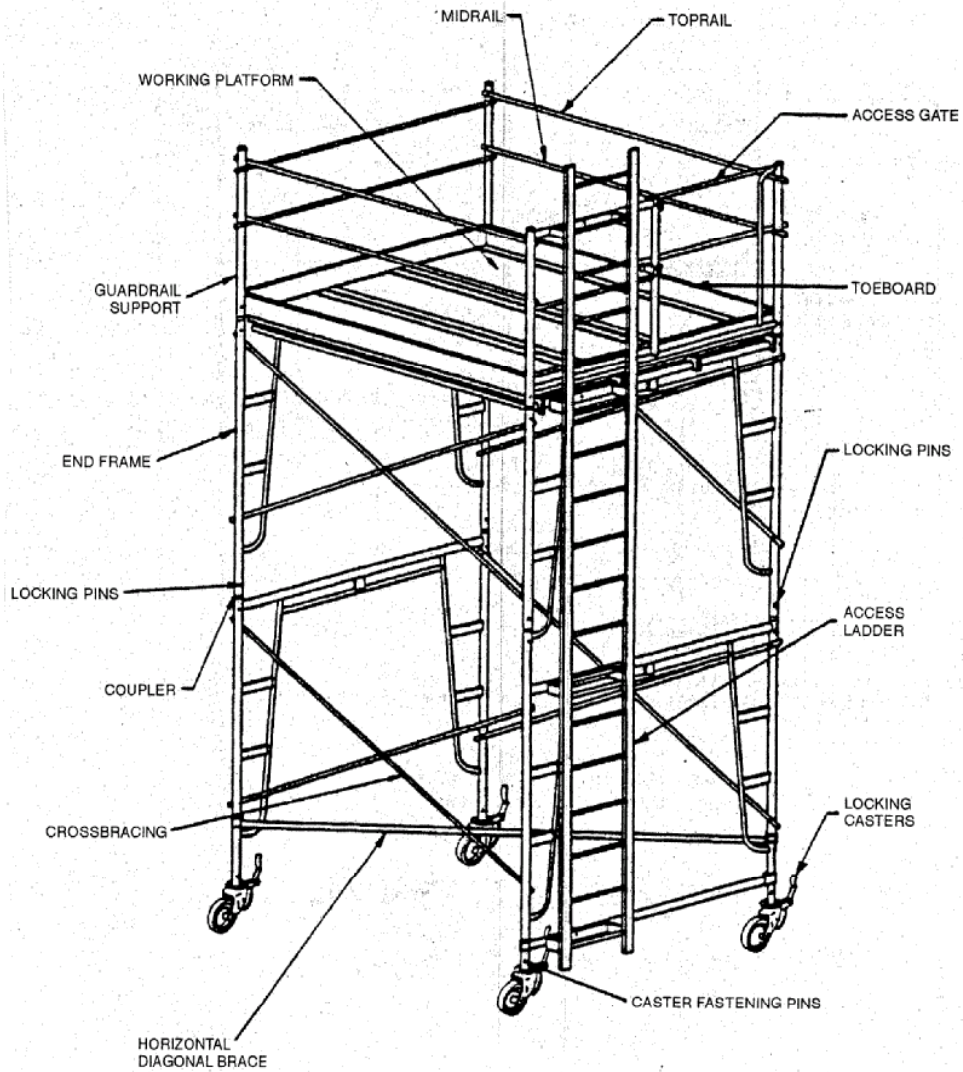

Manually Propelled Mobile Scaffold  
(Fabricated Tubular Frame)

FIGURE L-1 (CONTINUED)

SCAFFOLDS

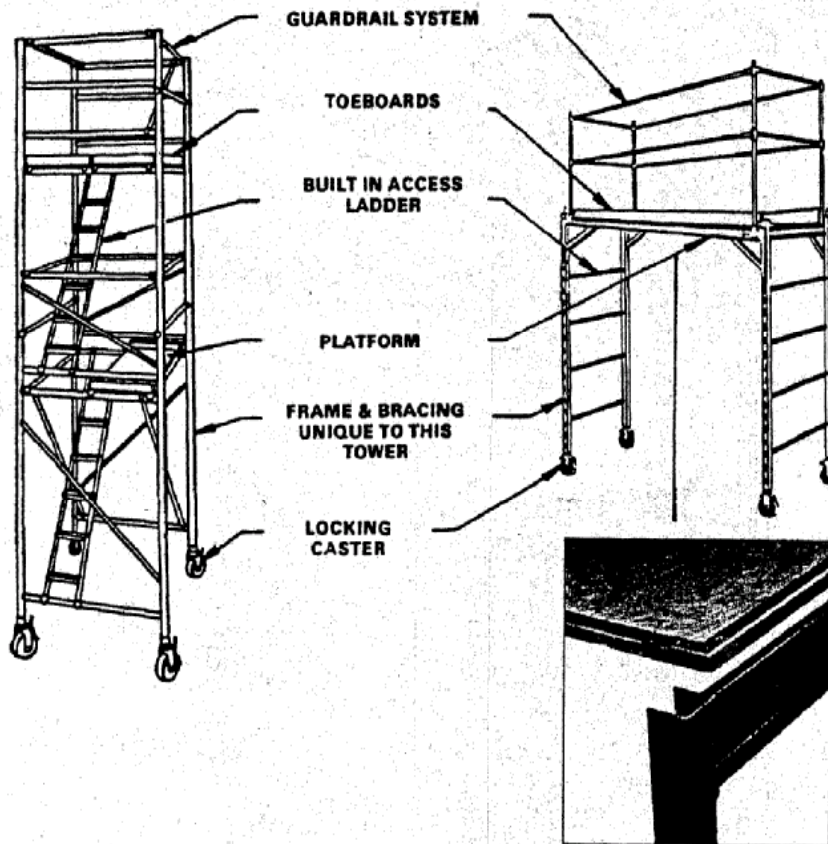

Truss and Platform

The platform is supported by the truss/support member. The truss is attached to the end frame/access ladder. The platform is secured in position through placement of the platform upon the inner ledge and within the side and end rails of the truss/support member.

Manually Propelled and  
Prefabricated Mobile Scaffolds

EM 385-1-1  
3 Nov 03

### FIGURE L-1 (CONTINUED)

### SCAFFOLDS

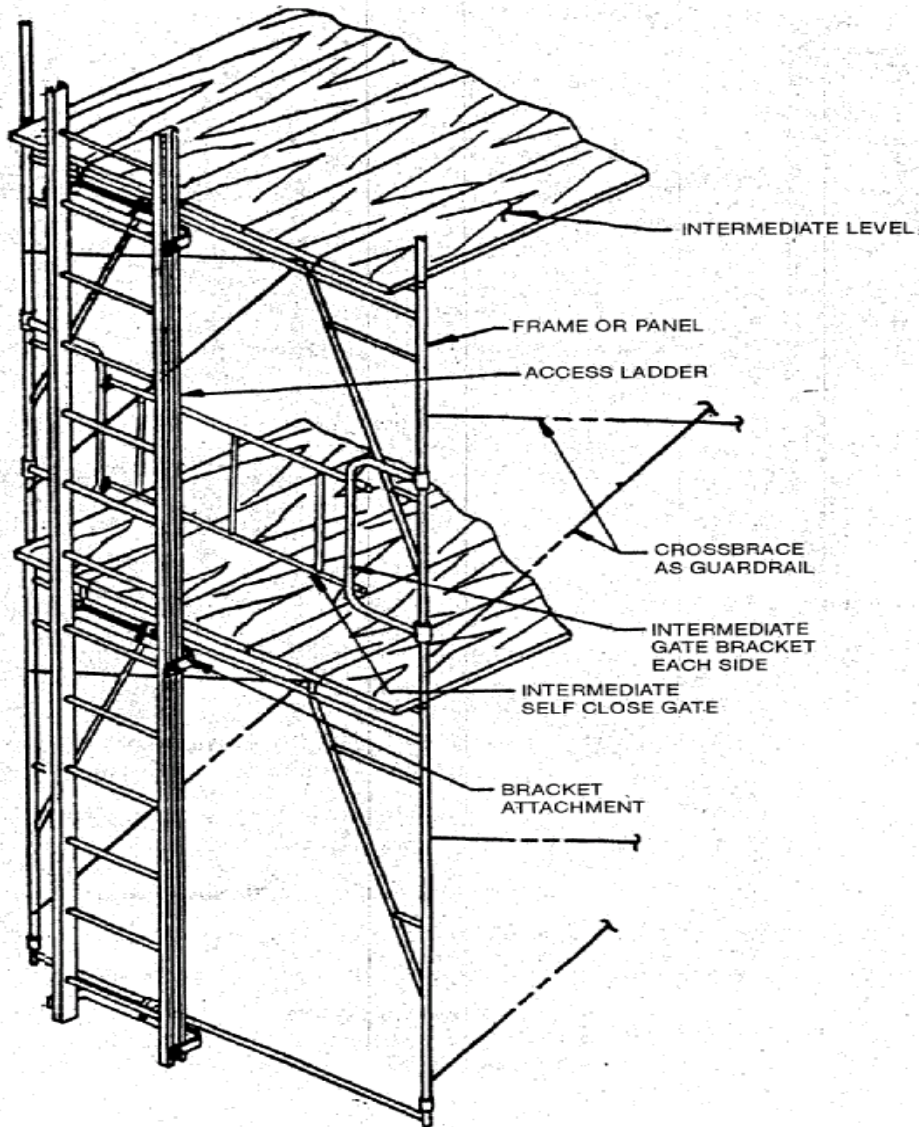

Frame Scaffold Access (2)

FIGURE L-1 (CONTINUED)

SCAFFOLDS

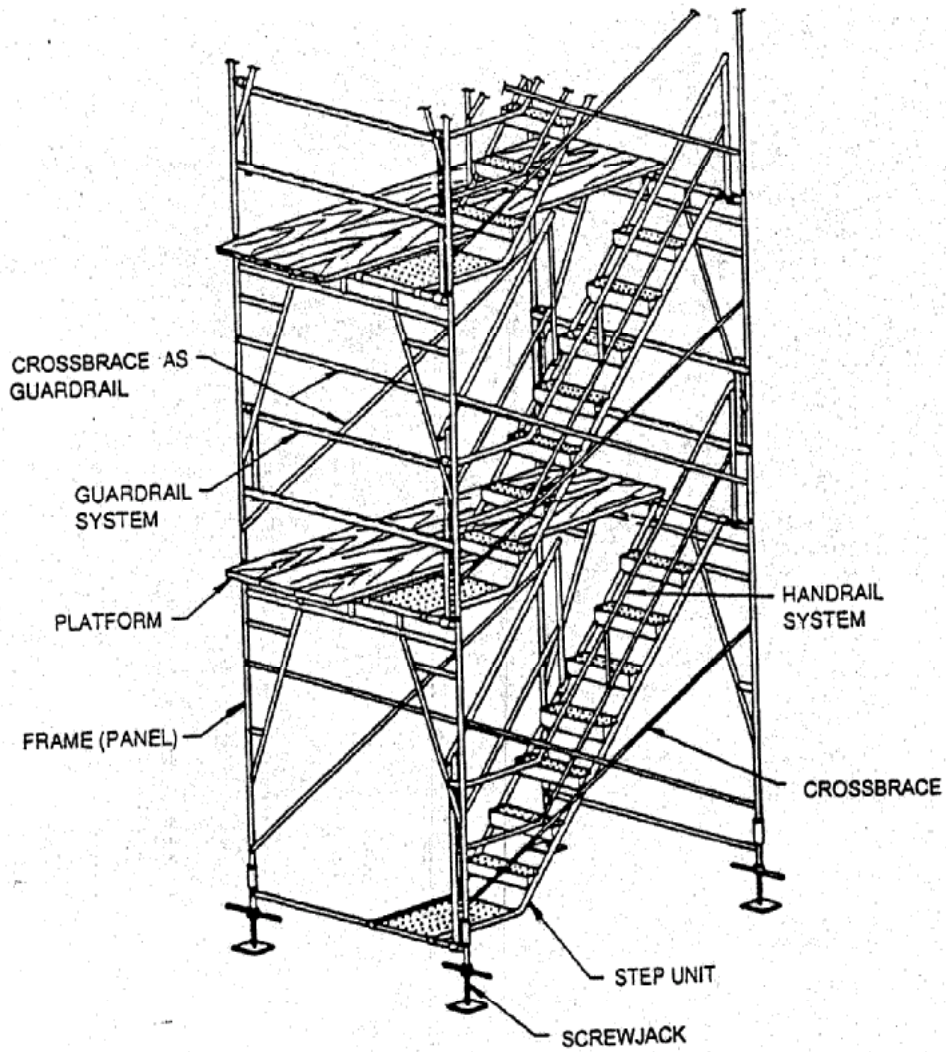

Frame Scaffold Access

EM 385-1-1  
3 Nov 03

### FIGURE L-1 (CONTINUED)

### SCAFFOLDS

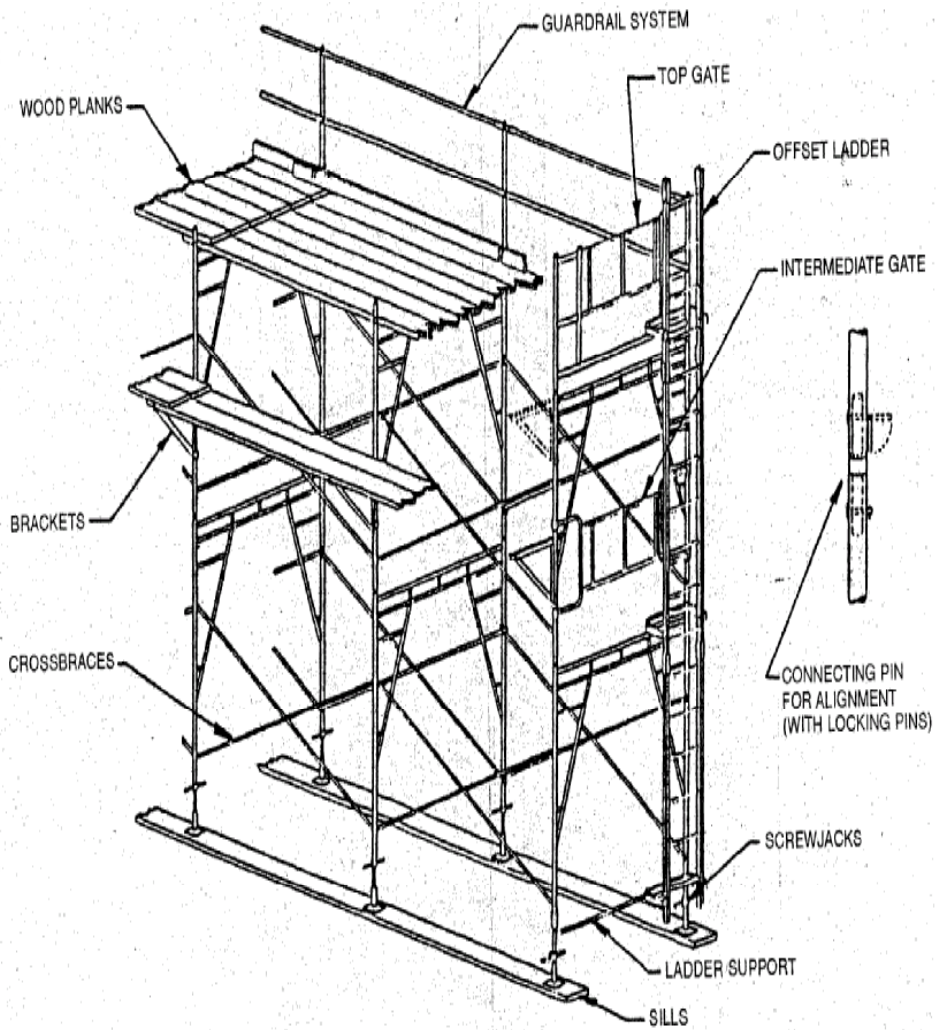

Fabricated Tubular Frame Scaffold



FIGURE L-1 (CONTINUED)

SCAFFOLDS

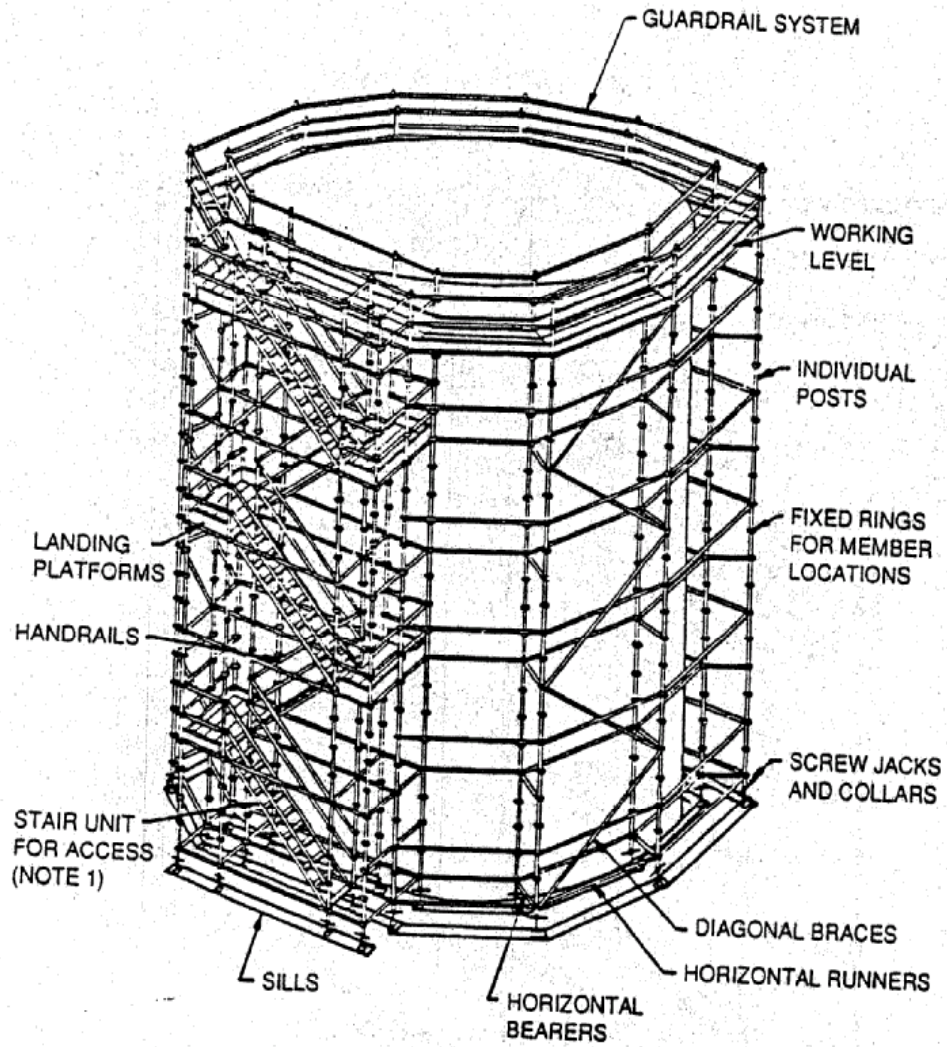

System Scaffold

FIGURE L-1 (CONTINUED)

SCAFFOLDS

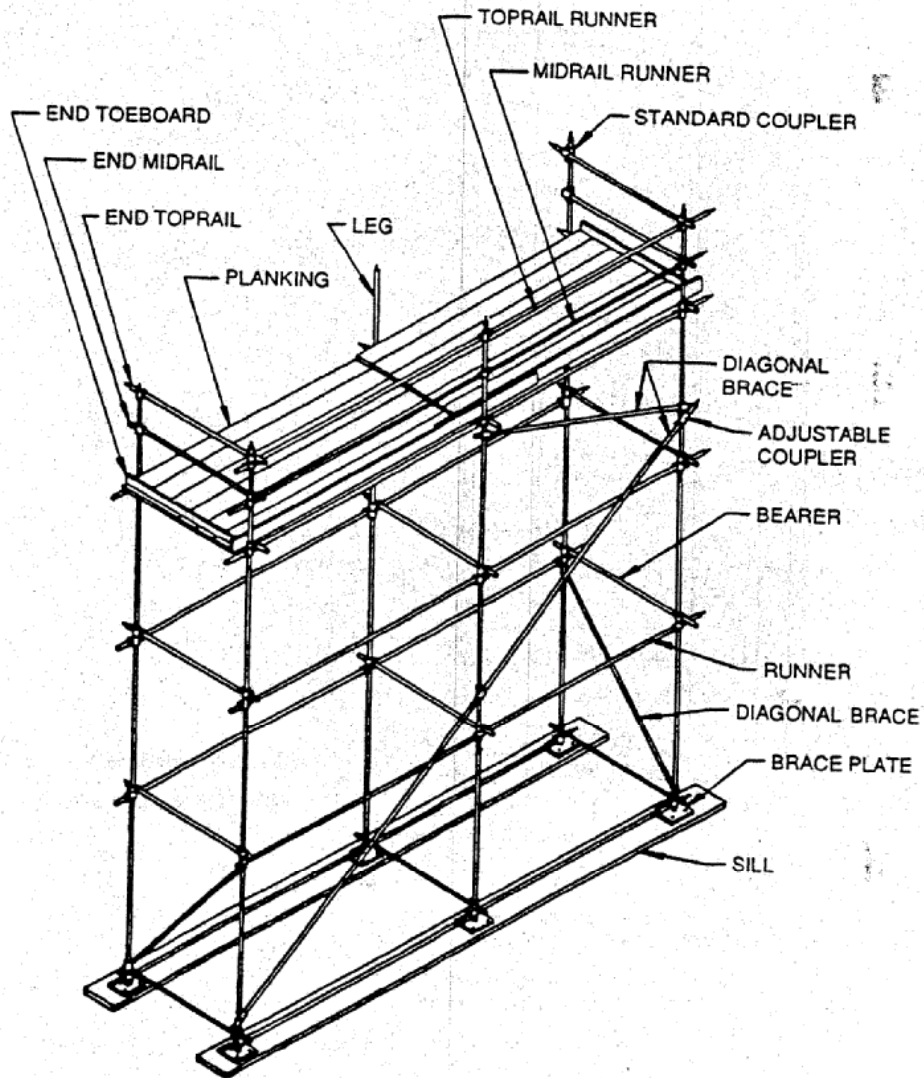

Tube and Coupler Scaffold

FIGURE L-1 (CONTINUED)

SCAFFOLDS

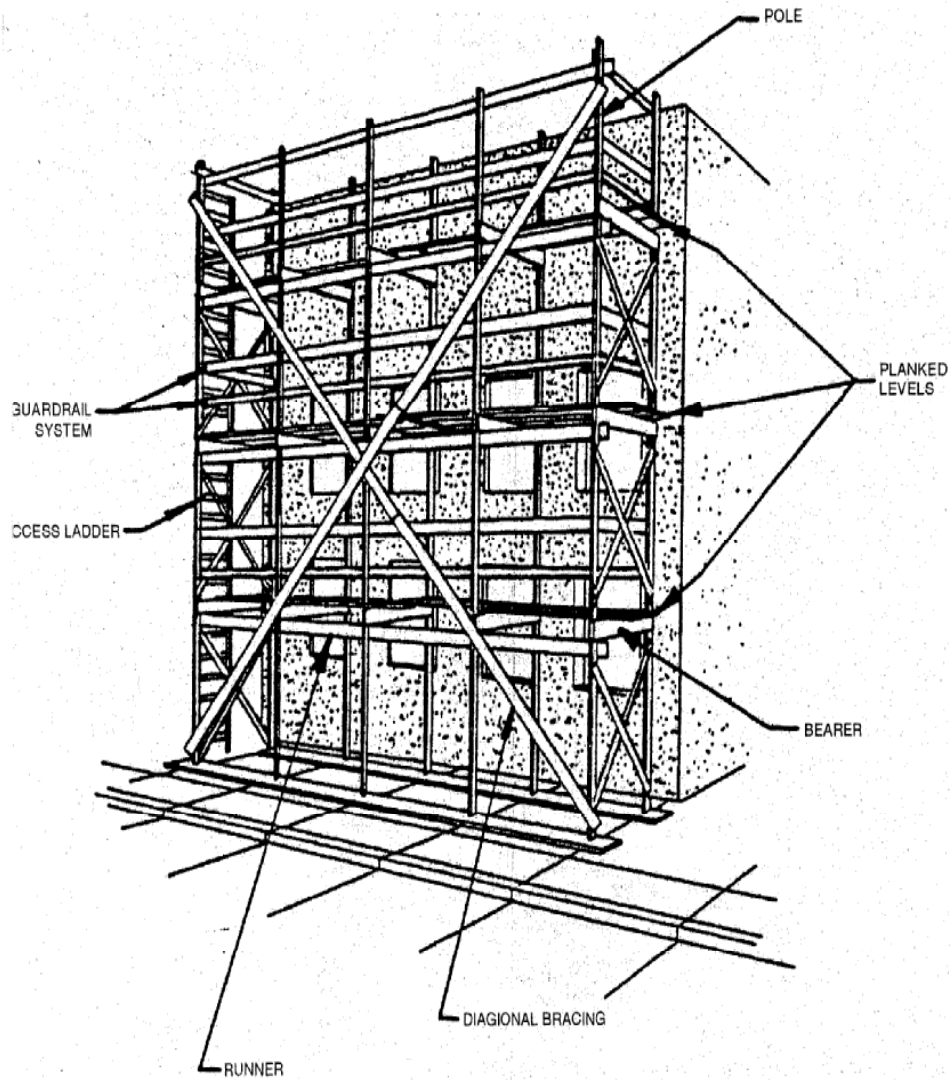

Wood Pole Scaffold

**FIGURE L-1 (CONTINUED)**

**SCAFFOLDS**

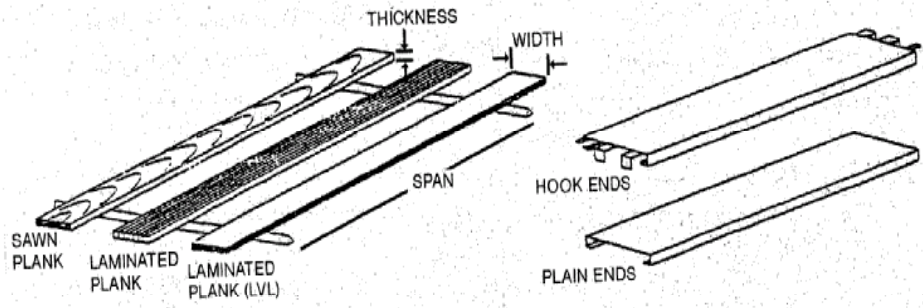

**Wood Planks**

**Metal Planks**

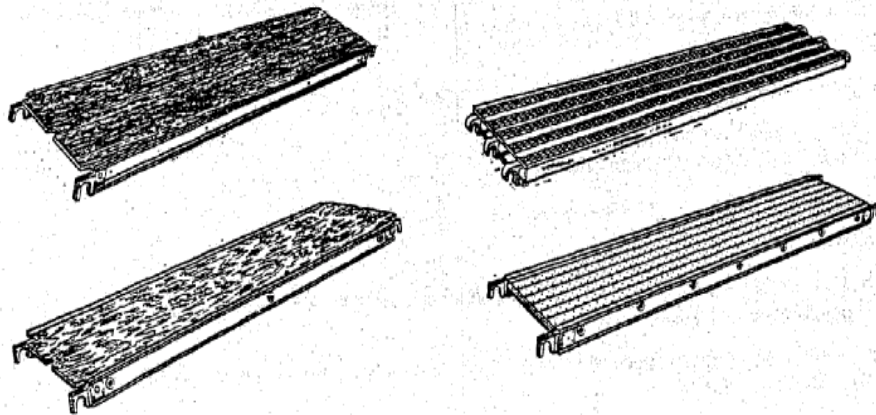

Scaffold Deck

FIGURE L-1 (CONTINUED)

SCAFFOLDS

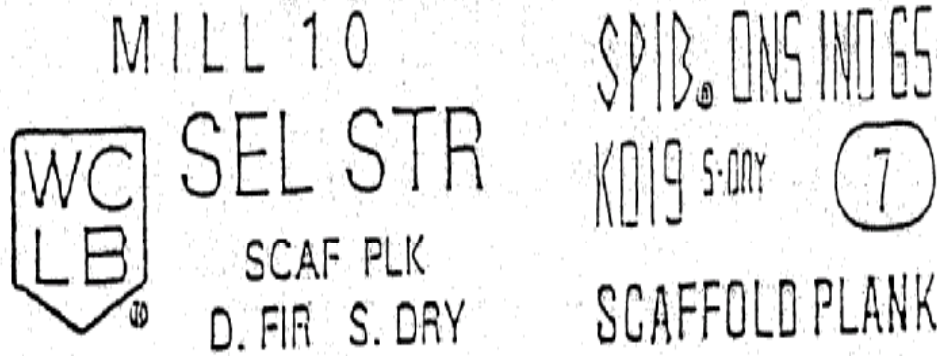

Examples of Grade Stamps

EM 385-1-1  
3 Nov 03

**FIGURE L-2**  
**WORK STANDS**

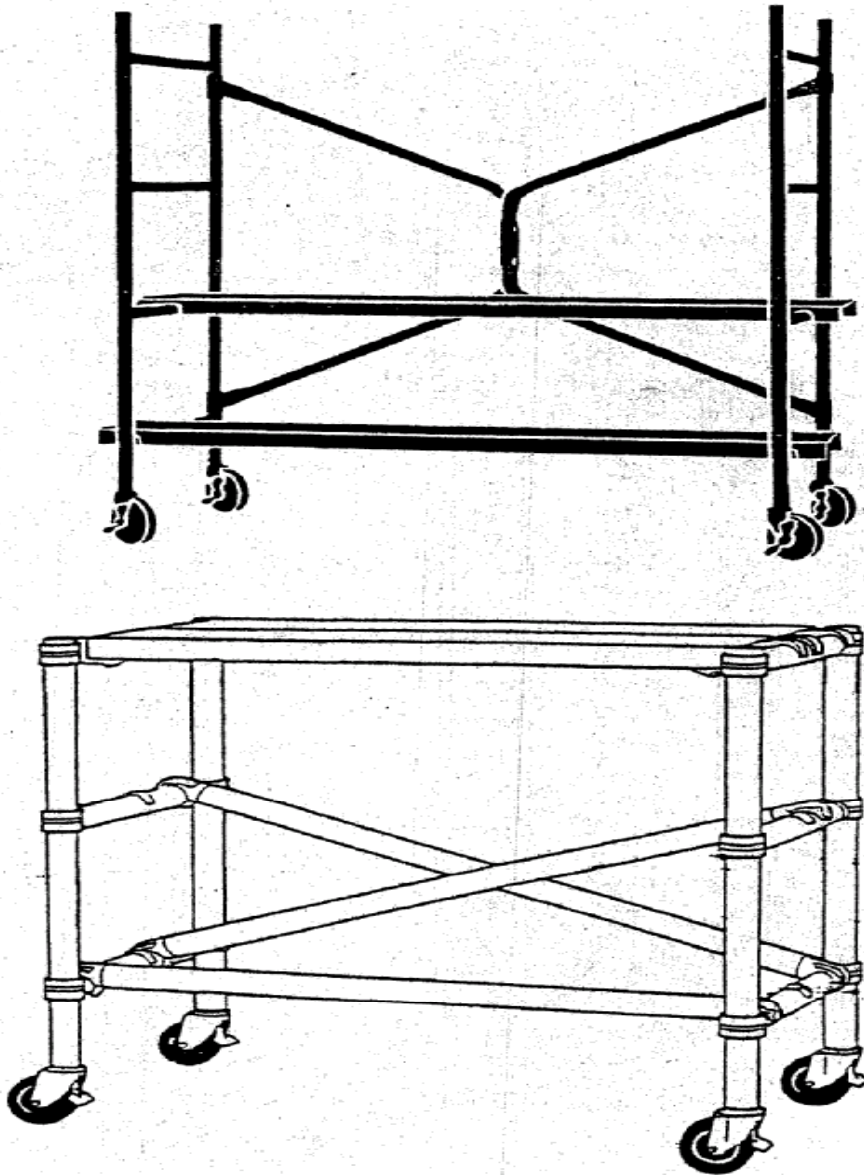

**Mobile Work Stands**

**FIGURE L-3**  
**PLATFORMS**

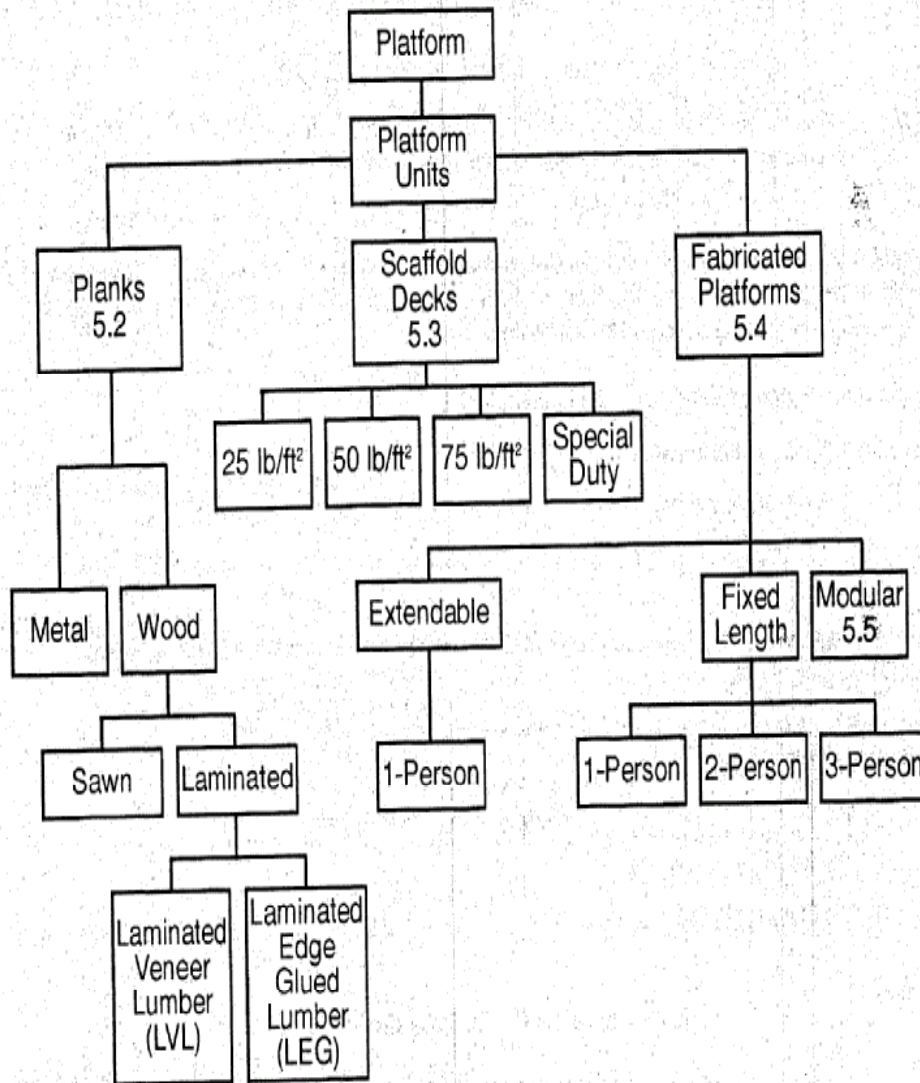

**Platform and Platform Unit Categorization Chart**

EM 385-1-1  
3 Nov 03

FIGURE L-3 (CONTINUED)

PLATFORMS

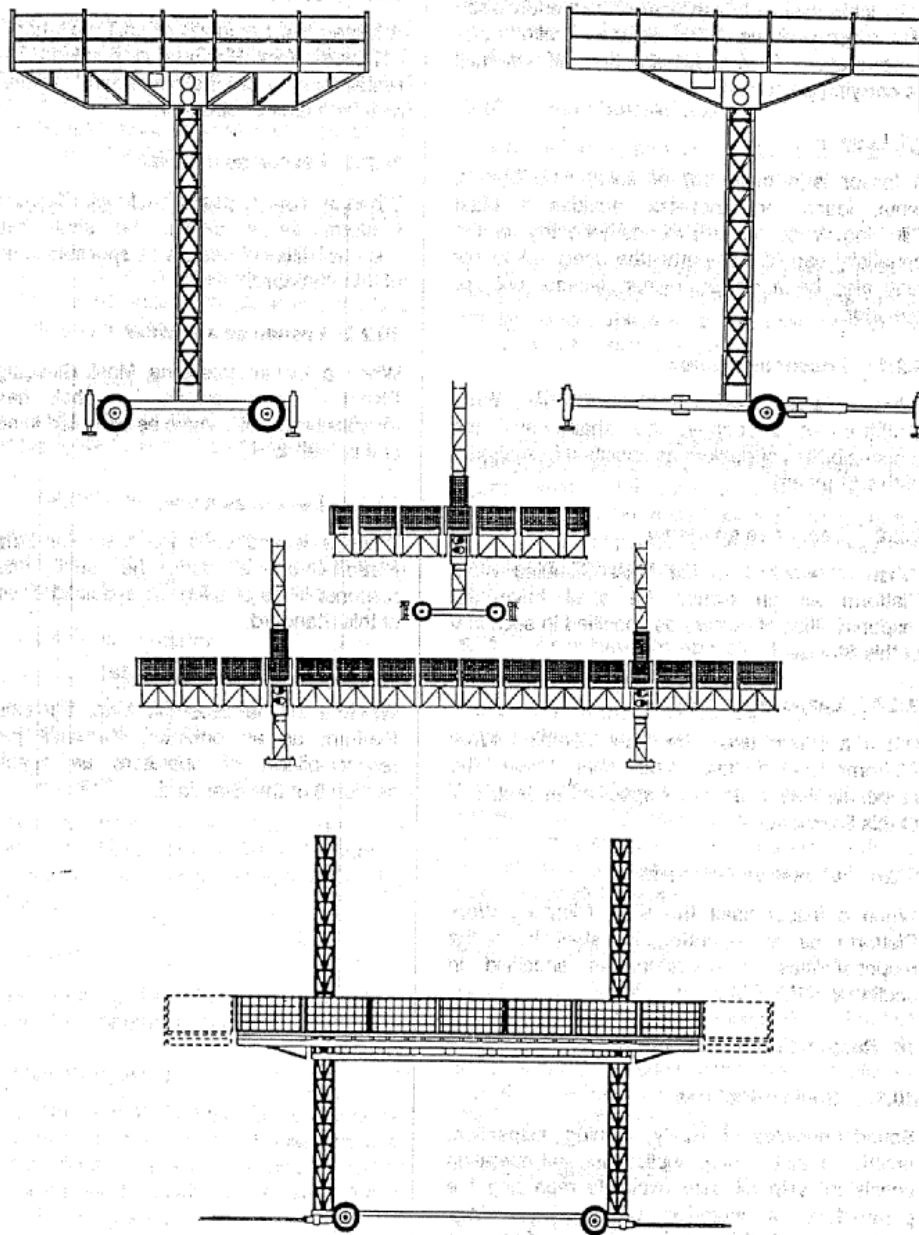



**FIGURE L-3 (CONTINUED)**

**PLATFORMS**

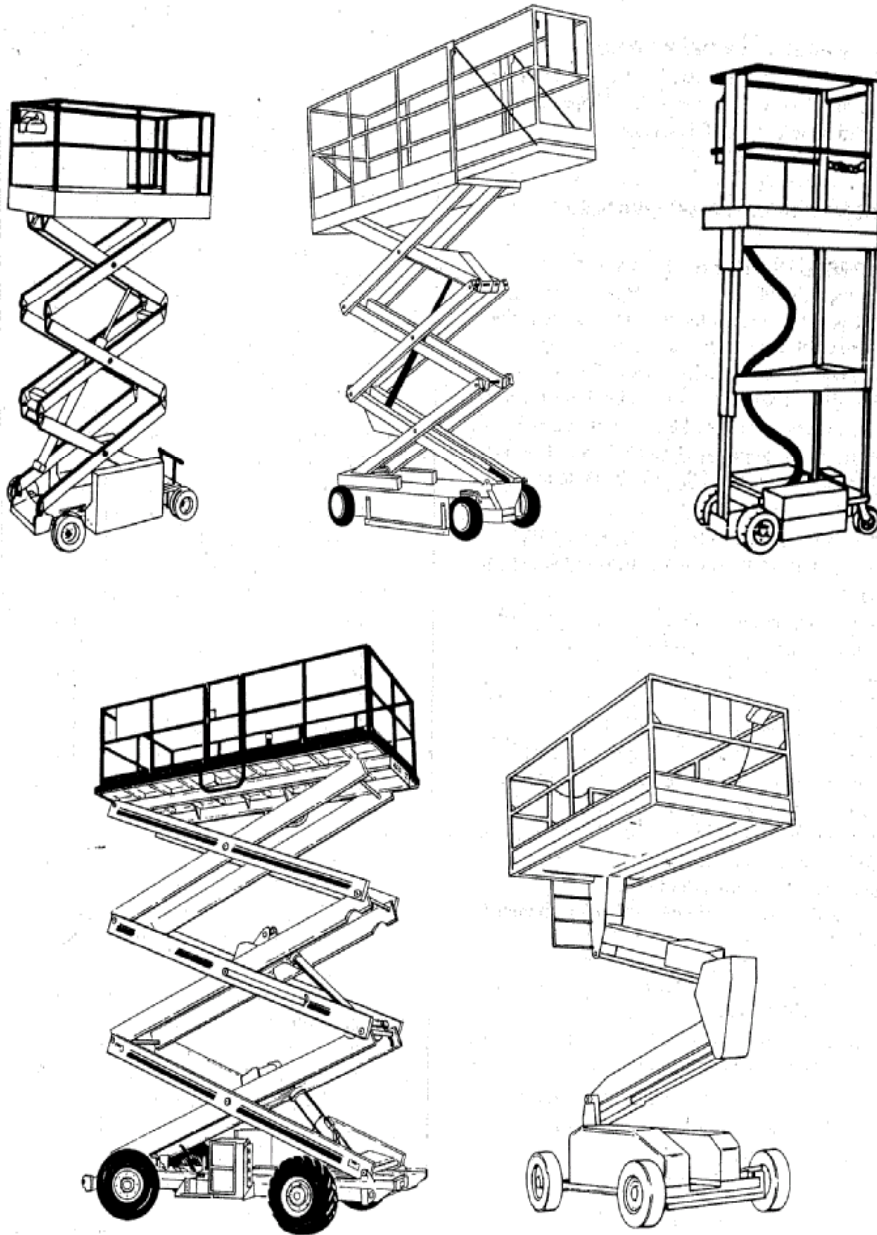

EM 385-1-1  
3 Nov 03

**FIGURE L-3 (CONTINUED)**

**PLATFORMS**

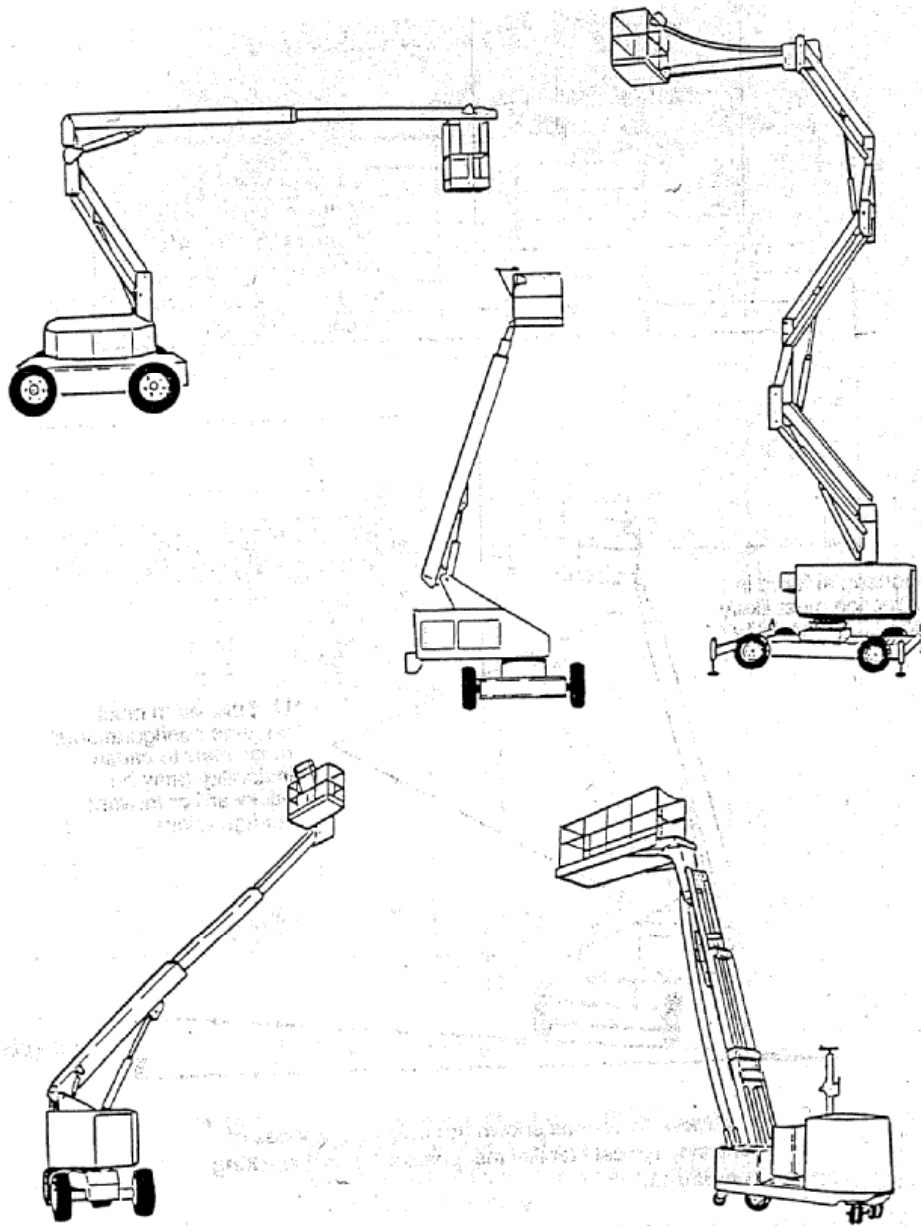

**FIGURE L-3 (CONTINUED)**

**PLATFORMS**

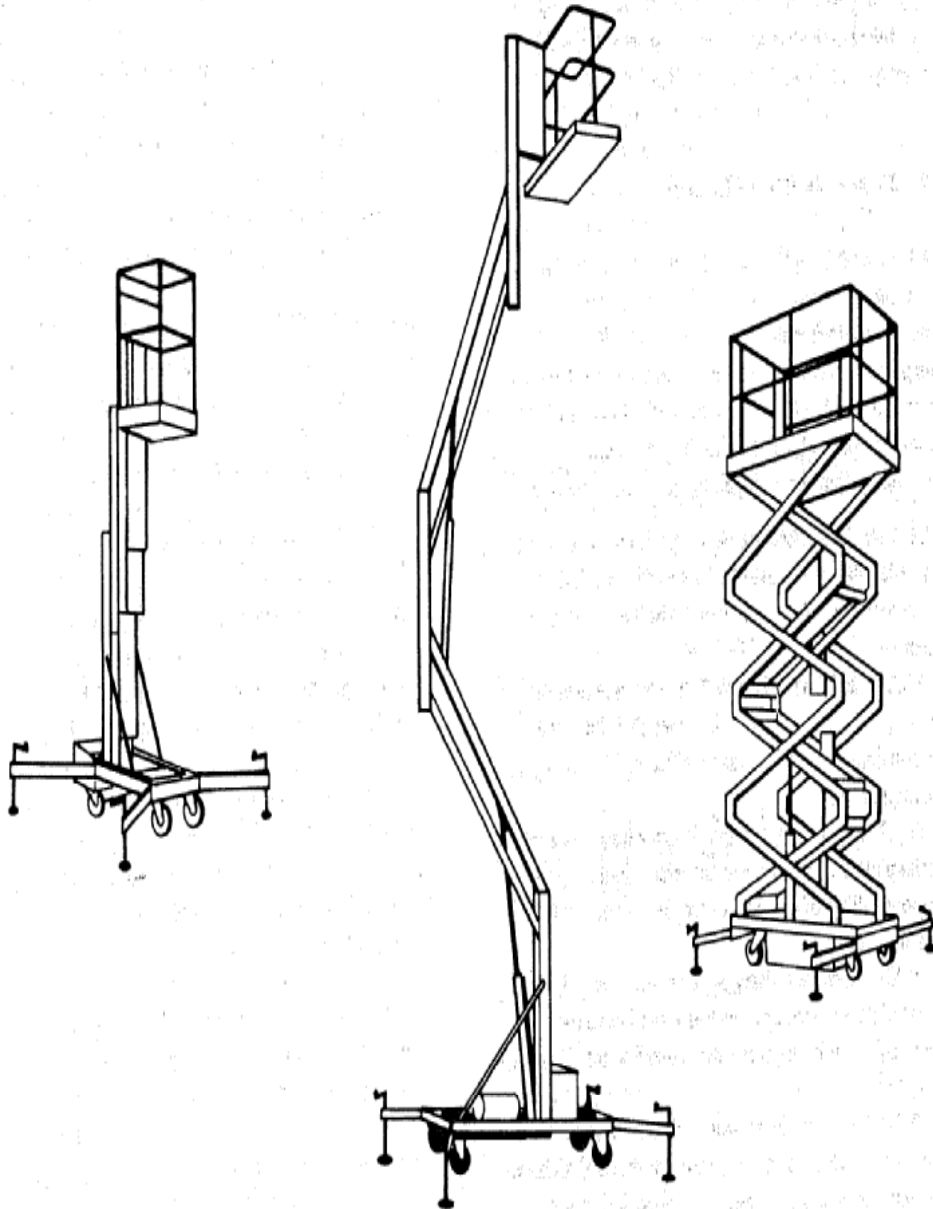

EM 385-1-1  
3 Nov 03

**FIGURE L-3 (CONTINUED)**

**PLATFORMS**

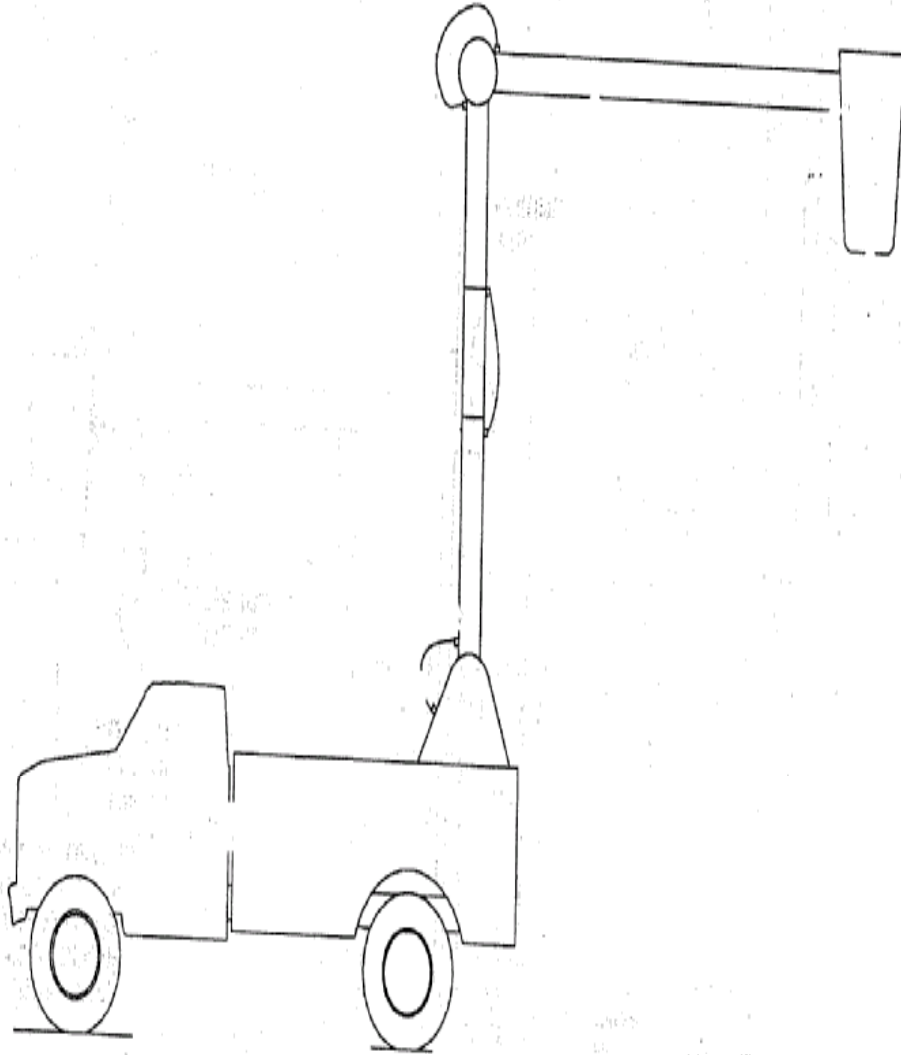

**FIGURE L-3 (CONTINUED)**

**PLATFORMS**

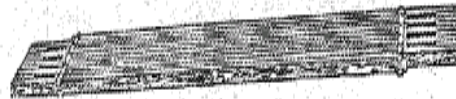
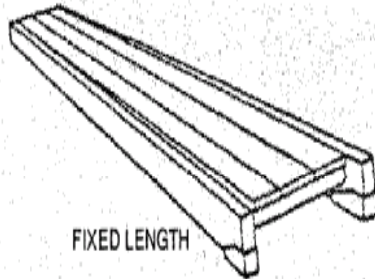

**Fabricated One-Person Platform**

